

SALT LAKE CITY ORDINANCE  
No. \_\_\_\_\_ of 2023

(Amending the zoning text of various sections of Title 21A of the *Salt Lake City Code* pertaining to building heights in the Downtown Plan area)

An ordinance amending the text of various sections of Title 21A of the *Salt Lake City Code* pertaining to building heights in the Downtown Plan area pursuant to Petition No. PLNPCM2022-00529.

WHEREAS, on August 24, 2022, the Salt Lake City Planning Commission (“Planning Commission”) held a public hearing on a petition submitted by Salt Lake City Mayor, Erin Mendenhall--at the request of the Salt Lake City Council--to amend land use regulations pertaining to building heights in the Downtown Plan area (Petition No. PLNPCM2022-00529); and

WHEREAS, at its August 24, 2022 meeting, the planning commission voted in favor of forwarding a positive recommendation to the Salt Lake City Council on said petition; and

WHEREAS, after a public hearing on this matter the city council has determined that adopting this ordinance is in the city’s best interests.

NOW, THEREFORE, be it ordained by the City Council of Salt Lake City, Utah:

SECTION 1. Amending the Text of Section 21A.26.070. That Section 21A.26.070 of the *Salt Lake City Code* (Zoning: Commercial Districts: CG General Commercial District), shall be and hereby is amended to read as follows:

**21A.26.070: CG GENERAL COMMERCIAL DISTRICT:**

- A. Purpose Statement: The purpose of the CG General Commercial District is to provide an environment for a variety of commercial uses, some of which involve the outdoor display/storage of merchandise or materials. This district provides economic development

opportunities through a mix of land uses, including retail sales and services, entertainment, office, residential, heavy commercial and low intensities of manufacturing and warehouse uses. This district is appropriate in locations where supported by applicable master plans and along major arterials. Safe, convenient and inviting connections that provide access to businesses from public sidewalks, bike paths and streets are necessary. Access should follow a hierarchy that places the pedestrian first, bicycle second and automobile third. The standards are intended to create a safe and aesthetically pleasing commercial environment for all users.

B. Uses: Uses in the CG General Commercial District as specified in Section 21A.33.030, “Table of Permitted and Conditional Uses for Commercial Districts”, of this title are permitted subject to the general provisions set forth in Section 21A.26.010 and this section.

C. Minimum Lot Size:

1. Minimum Lot Area: 10,000 square feet.
2. Minimum Lot Width: 60’.
3. Existing Lots: Lots legally existing prior to April 12, 1995, shall be considered legal conforming lots.

D. Minimum Yard Requirements:

1. Front Yard: Five feet.
2. Corner Side Yard: 10’.
3. Interior Side Yard: None required.
4. Rear Yard: 10’.
5. Buffer Yard: All lots abutting residential property shall conform to the buffer yard requirements of Chapter 21A.48 of this title.
6. Accessory Buildings and Structures in Yards: Accessory buildings and structures may be located in a required yard subject to Section 21A.36.020, Table 21A.36.020.B of this title.

E. Maximum Yard: The maximum yard requirement is 10’.

1. If provided, the yard must include one of the following elements:
  - a. Seating at a ratio of at least one bench for every 500 square feet of yard space; or
  - b. Landscaping that includes an increase of at least 25% in the total number of trees required to be planted on the site; or
  - c. Awning or a similar form of weather protection that covers at least five feet in width and length from all street-facing building entrances.

2. Regardless of the setback provided, doors shall be setback a minimum distance to allow the door to operate without swinging into a right of way or midblock walkway.
  3. All provided front or corner side yards must contain a tree every 30’.
  4. The planning director, in consultation with the transportation director, may modify this requirement to accommodate a wider sidewalk if the adjacent public sidewalk is less than 15’ wide and the resulting modification to the setback results in a more efficient public sidewalk. The planning director may waive this requirement for any addition, expansion, or intensification, which increases the floor area or parking requirement by less than 50% if the planning director finds the following:
    - a. The architecture of the addition is compatible with the architecture of the original structure or the surrounding architecture, or
    - b. The addition reduces the extent of the noncompliance of the existing building.
  5. Exceptions to this subsection may be authorized through the design review process, subject to the requirements of Chapter 21A.59 of this title.
- F. Landscape Yard Requirements: A landscape yard of five feet shall be required on all front or corner side yards, conforming to the requirements of Section 21A.48.090 of this title.
- G. Maximum Height: No building shall exceed 75’ unless the property is within the following boundary: from 400 South to 700 South from 300 West to I-15, where buildings shall not exceed 150’. Additionally, buildings taller than 75’ to a maximum of 105’ outside of the described boundary may be allowed in accordance with the provisions of Subsections G.1 through G.3 of this section.

Illustration of Regulation 21A.26.070.G Maximum Height

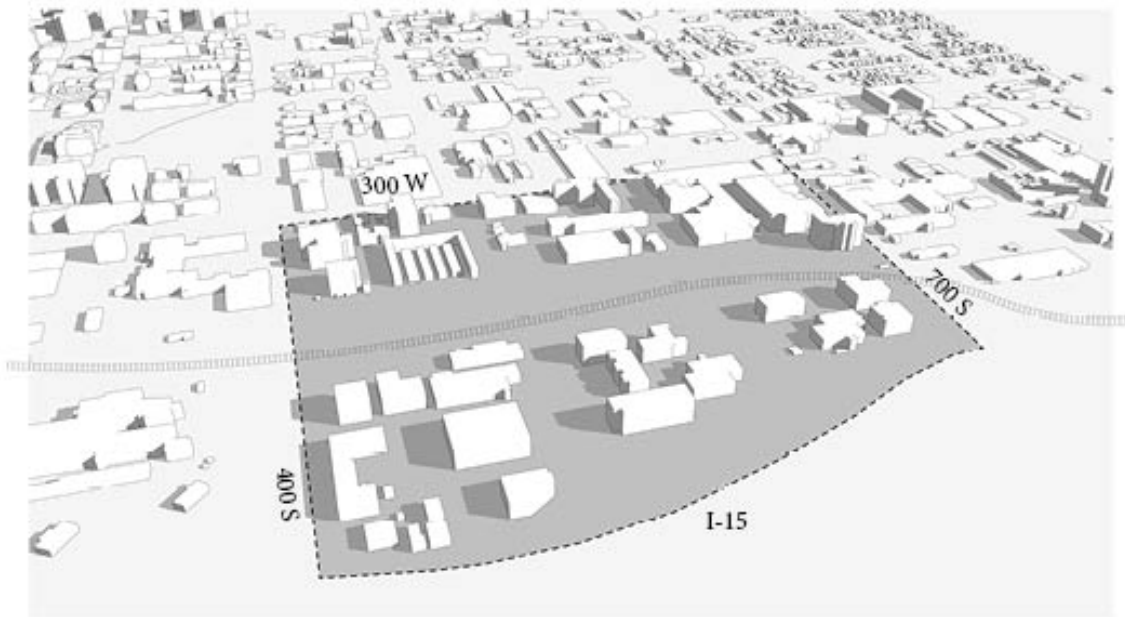

1	No building shall exceed 75' unless it is within the identified boundaries.
2	Buildings that are outside of the identified boundary higher than 75' may be allowed in accordance with the provisions of Subsections G.1 through G.3 of this section.

1. Procedure For Modification: A modification to the height regulations, in this Subsection G may be granted through the design review process in conformance with the provisions of Chapter 21A.59 of this title. In evaluating an application submitted pursuant to this section, the planning commission or in the case of an administrative approval the planning director or designee, shall find that the increased height will result in improved site layout and amenities.
2. Outdoor Usable Space: If additional height is approved, the site shall include outdoor usable space for the building occupants that is equal to at least 10% of the gross floor area of the additional floors. The outdoor usable area may be located within a wider park strip that extends further into the right of way than the current park strip, in midblock walkways that include a public access easement, in rooftop gardens, plazas, or in a provided yard that exceeds the minimum yard requirement. The outdoor usable space shall include a minimum dimension of at least 10' by 10'.
3. Maximum Additional Height for Properties Outside of Boundary Identified in Subsection G: Additional height shall be limited to 30' subject to the provisions in Subsection G.2 for a maximum height of 105'.

H. Midblock Walkways: As part of the city’s plan for the downtown area, it is intended that midblock walkways be provided to facilitate pedestrian movement within the area. The city has adopted the Downtown Plan that includes a midblock walkway map and establishes a need for such walkways as the Downtown area grows. Because the districts within the downtown area allow building heights that exceed those of other districts in the city, the requirement for a midblock walkway is considered to be necessary to alleviate pedestrian impacts on the public sidewalks by dispersing future use of the public sidewalks. This requirement implements the city’s Downtown Plan and provides visual relief from the additional height that is available in these zone districts when compared to the remainder of the city. All buildings constructed after the effective date hereof within the Downtown zoning districts shall conform to this officially adopted plan for midblock walkways, in addition to the following standards:

1. Any new development shall provide a midblock walkway if a midblock walkway on the subject property has been identified in a master plan that has been adopted by the city.
2. The following standards apply to the midblock walkway:
  - a. The midblock walkway must be a minimum of 15’ wide and include a minimum 6’ wide unobstructed path.
  - b. The midblock walkway may be incorporated into the building provided it is open to the public. A sign shall be posted indicating that the public may use the walkway.
  - c. Building encroachments into the midblock walkway are permitted if they include one or more of the following elements:
    - (1) Colonnades;
    - (2) Staircases;
    - (3) Balconies – All balconies must be located at the third story or above;
    - (4) Building overhangs and associated cantilever - These coverings may be between 9’ and 14’ above the level of the sidewalk. They shall provide a minimum depth of coverage of six feet and project no closer to the curb than three feet;
    - (5) Skybridge – A single skybridge is permitted. All skybridges must be located at the third, fourth, or fifth stories; and
    - (6) Other architectural element(s) not listed above that offers refuge from weather and/or provide publicly accessible usable space.

Illustration of Regulation 21A.26.070.H Midblock Walkways

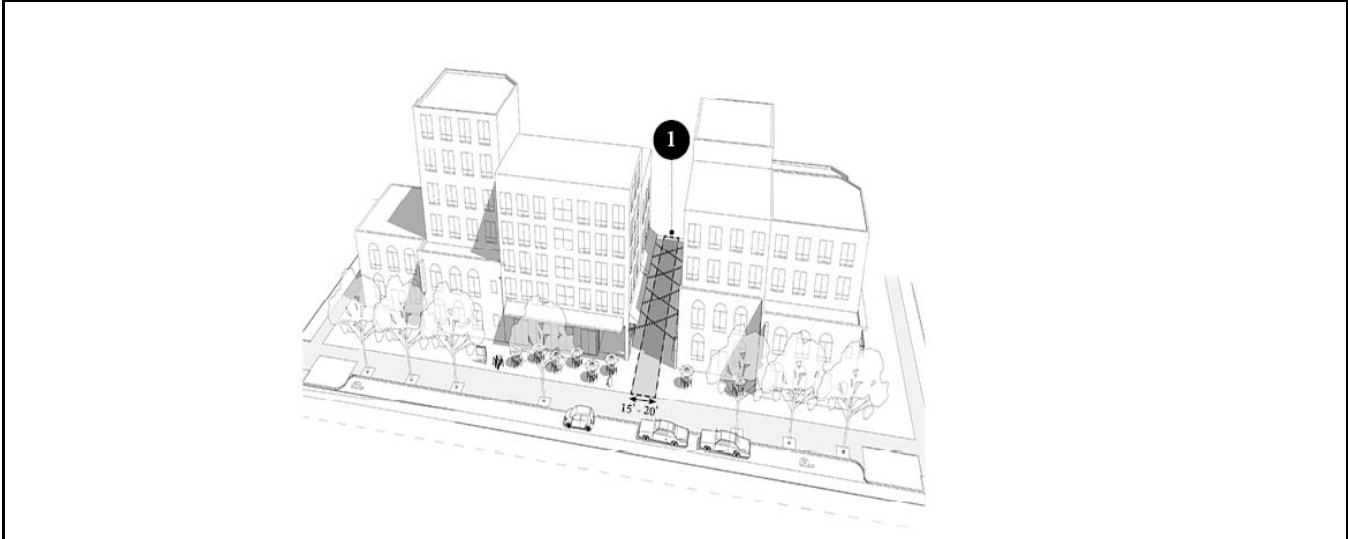

1	The midblock walkway must be a minimum of 15’ wide and include a minimum 6’ wide unobstructed path.
---	---

I. Restrictions on Parking Lots and Structures: An excessive amount of at or above ground parking lots and structures can negatively impact the urban design objectives of the General Commercial (CG) District. To control such impacts, the following regulations shall apply to parking facilities that are at or above ground:

1. Parking shall be located behind principal buildings or incorporated into the principal building provided the parking is wrapped on street facing facades with a use allowed in the zone other than parking.
2. Parking lots not wholly behind the principal building are limited to no more than two double-loaded parking aisles (bays) adjacent to each other. The length of a parking lot shall not exceed 10 stalls.
3. No special restrictions shall apply to belowground parking facilities.
4. Parking structures shall conform to the requirements set forth in Chapter 21A.37 of this title.
5. All parking lot and structure landscaping must comply with the provisions set forth in Chapter 21A.48 of this title.

SECTION 2. Amending the Text of Section 21A.27.020. That Section 21A.27.020 of the *Salt Lake City Code* (Zoning: Form Based Districts: Building Types and Forms Established), shall be and hereby is amended to read as follows:

## **21A.27.020: BUILDING TYPES AND FORMS ESTABLISHED:**

### **A. Building Types and Form Standards:**

1. Encourage building forms that are compatible with the neighborhood and the future vision for the neighborhood by acknowledging the current scale of the area and its architectural and material elements. These elements within new development shall compliment those of the existing buildings;
2. Arrange building heights and scale to provide appropriate transitions between buildings of different scales and adjacent areas, especially between different subdistricts;
3. Guide building orientation through setbacks and other requirements to create a consistent street edge, enhance walkability by addressing the relationship between public and private spaces, and ensure architectural design will contribute to the character of the neighborhood;
4. Use building form, placement, and orientation to identify the private, semiprivate, and public spaces;
5. Minimize the visual impact of parking areas; and
6. Minimize conflicts between pedestrians, bicyclists, and vehicles.

### **B. Building Types and Forms:**

1. Description: The permitted building forms are described in this subsection. Each building form includes a general description and definition, as well as images of what the building form may look like. Building form images are for informational purposes only and not intended to demonstrate exactly what shall be built. The description and images should be used to classify existing and proposed buildings in order to determine what development regulations apply. The drawings are not to scale. They should not be used to dictate a specific architectural style as both traditional and contemporary styles can be used.
  - a. Urban House: A residential structure with the approximate scale of a single dwelling unit, as viewed from the street, but may contain up to two dwelling units. The structure has a single entry facing the street, a front porch or stoop, and a small front yard. Second units may be arranged vertically (up and down) or horizontally (front and back), but the entry to the second unit is from the side, rear, or interior of structure. A third unit may also be located along an alley as a stand alone unit or as a dwelling unit located in an accessory building. All units are on a single lot.

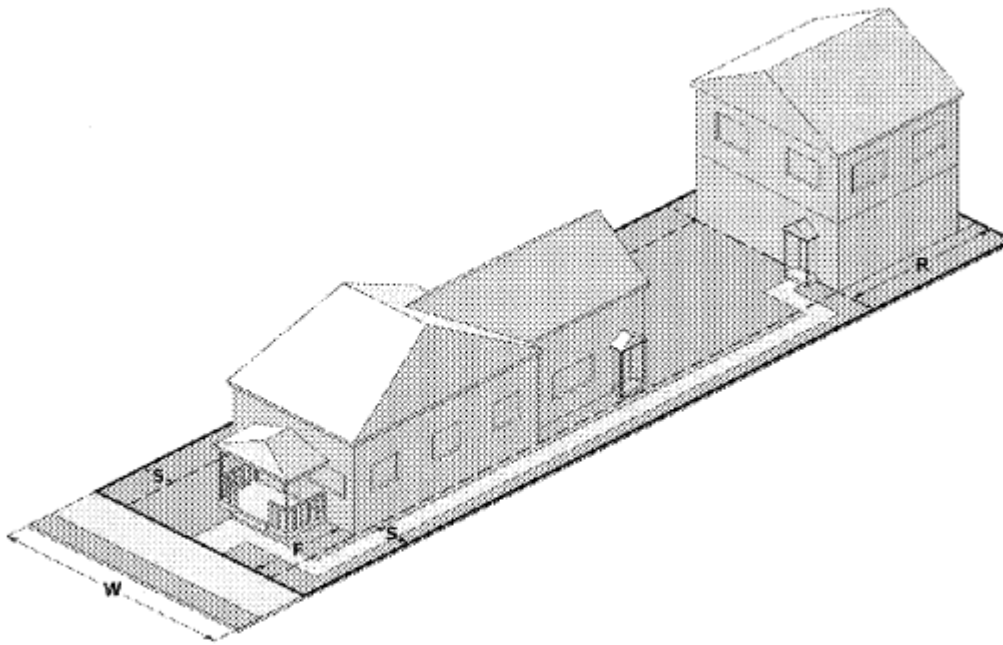

Urban House With Detached Dwelling



Modern And Traditional Forms



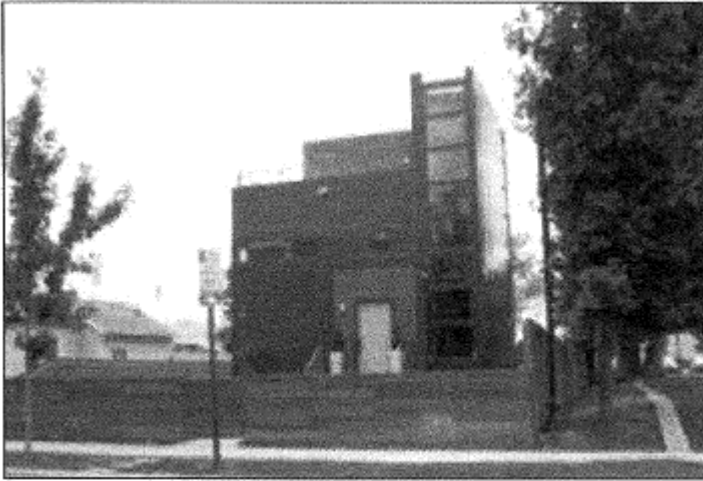

Two-Story Contemporary Form

- b. Two-Family Dwelling: A residential structure that contains two dwelling units in a single building. The units may be arranged side by side, up and down, or front and back. Each unit has its own separate entry directly to the outside. Dwellings may be located on separate lots or grouped on one lot. A third unit may also be located along an alley as a stand alone unit or as a dwelling unit located in an accessory building, but may not be located on a separate lot.

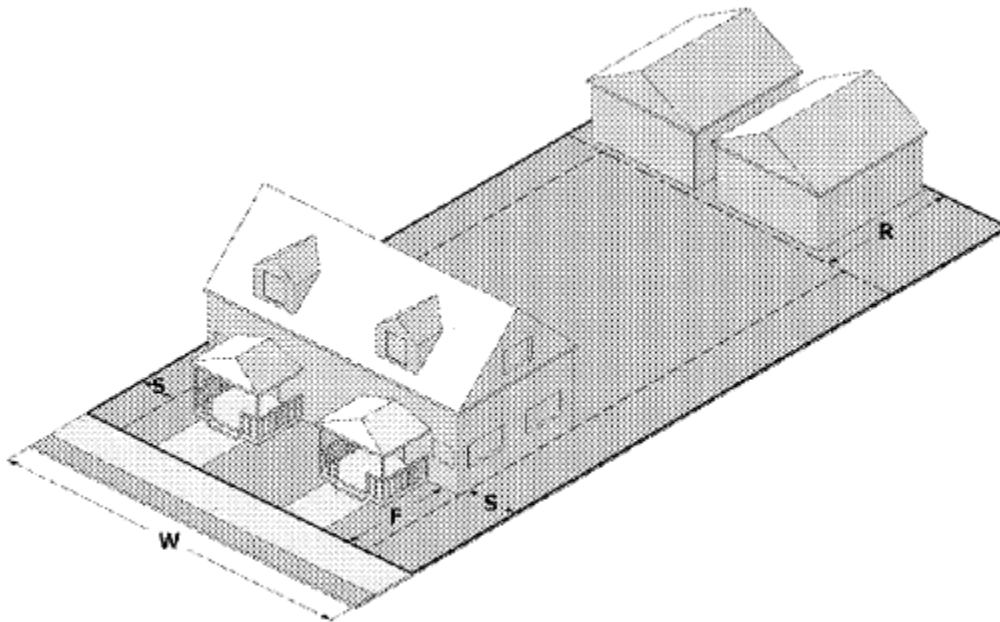

Two-Family Dwelling With Garages

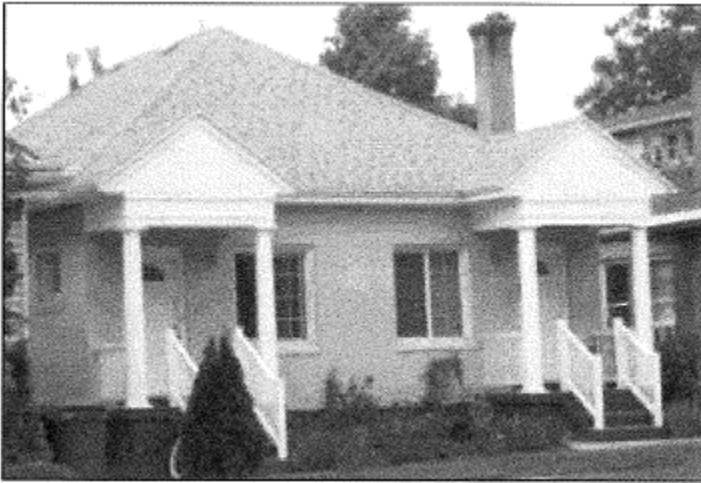

Traditional Two-Family Dwelling



Modern Two-Family Dwelling

- c. Cottage Development: A unified development that contains two or more detached dwelling units with each unit appearing to be a small single-family dwelling with

a common green or open space area. Dwellings may be located on separate lots or grouped on one lot.

d. Additional Development Standards for Cottage Building Forms:

- (1) Setbacks Between Individual Cottages: All cottages shall have a minimum setback of eight feet from another cottage.
- (2) Footprint: No cottage shall have a footprint in excess of 850 square feet.
- (3) Building Entrance: All building entrances shall face a public street or a common open space area.
- (4) Open Space Area: A minimum of 250 square feet of common, open space area is required per cottage. At least 50% of the open space area shall be contiguous and include landscaping, walkways or other amenities intended to serve the residents of the development.

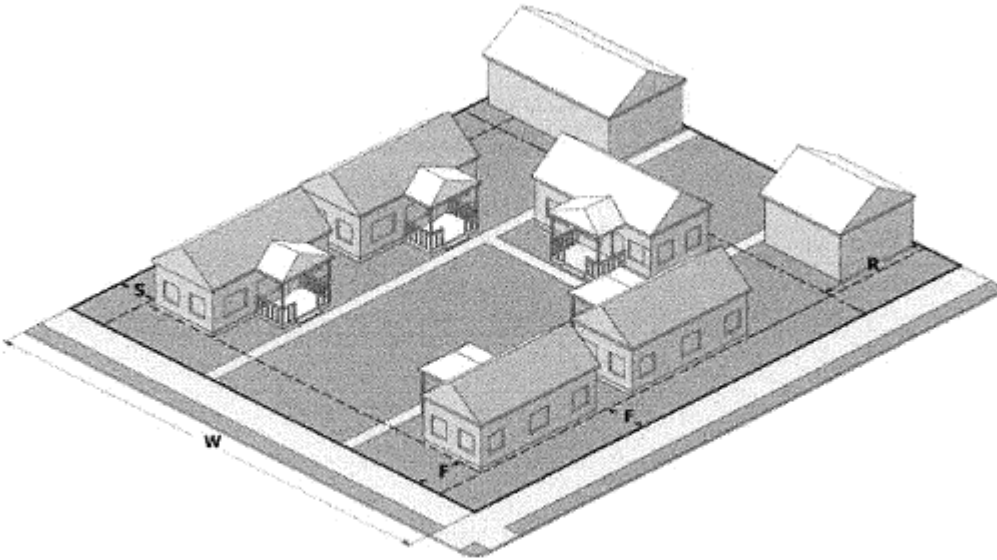

Cottage Development On Single Parcel



Cottage Development

- e. Row House: A series of attached single-family dwellings that share at least one common wall with an adjacent dwelling unit. A row house contains a minimum of three residential dwelling units. Each unit may be on its own lot. If possible, off street parking is accessed from an alley.

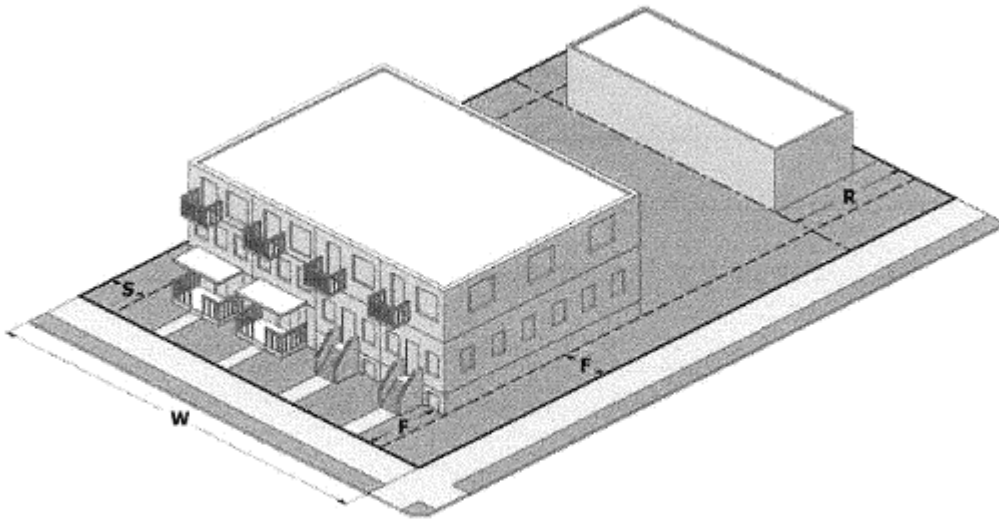

Row House On Single Parcel



Modern Row House Form



Traditional Row House Form

- f. Multi-Family Residential: A multi-family residential structure containing three or more dwelling units that may be arranged in a number of configurations.

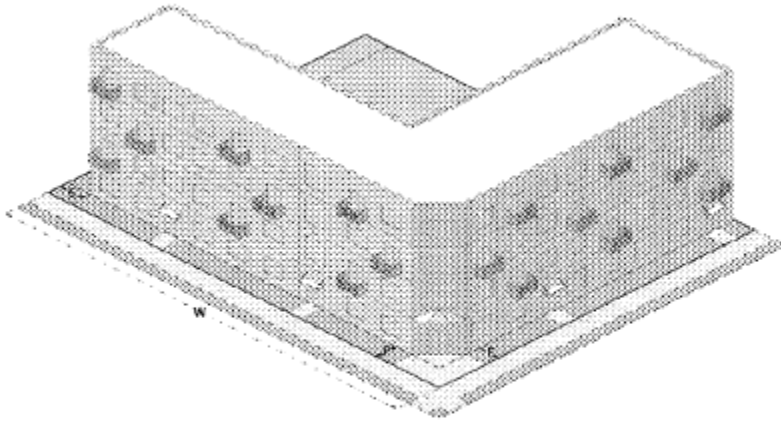

Multi-Family Residential Form



Multi-Family Modern Form

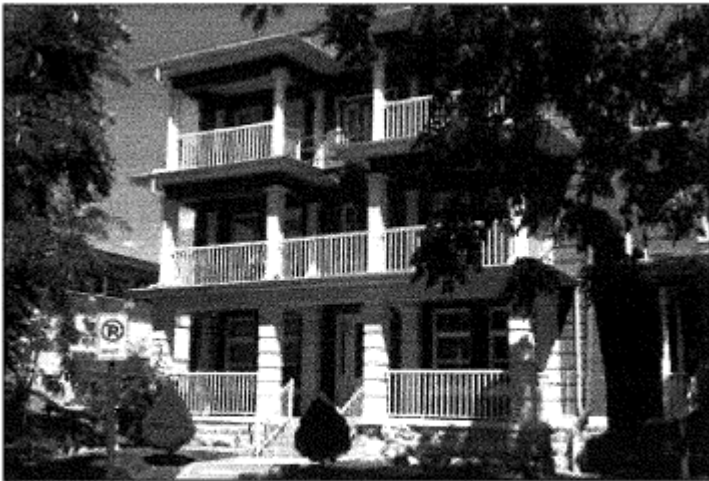

Multi-Family Traditional Form

- g. Storefront: A commercial structure that may have multiple stories and contain a variety of commercial uses that are allowed in the district that permits this building type. All buildings, regardless of the specific use, have a ground floor that looks like a storefront.



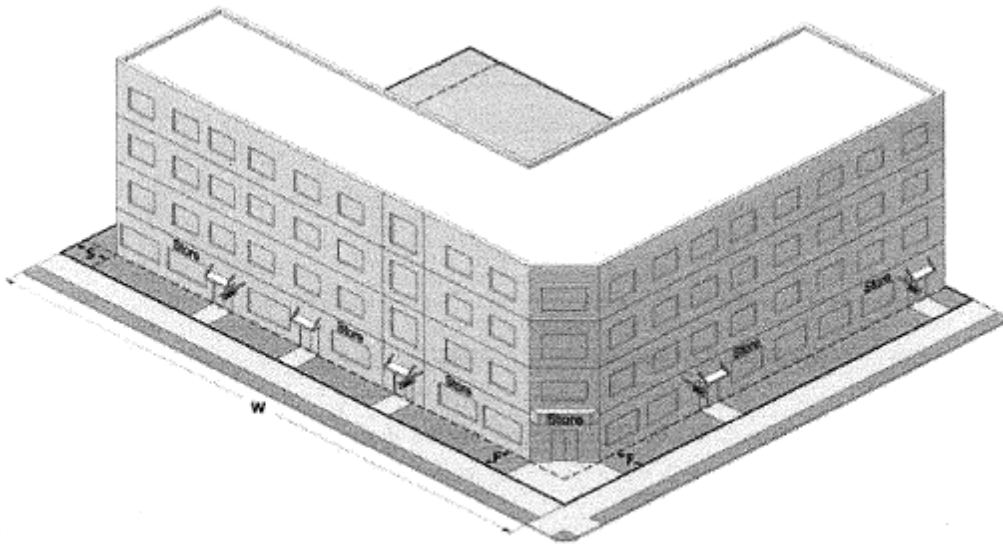

Storefront Form

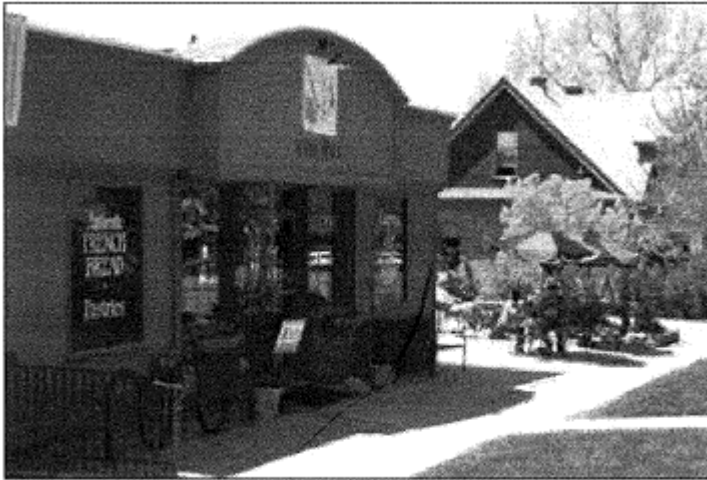

Contemporary Storefront



Traditional Storefront

- h. Vertical Mixed Use: A multi-story building that contains a mix of commercial and/or office with residential uses.

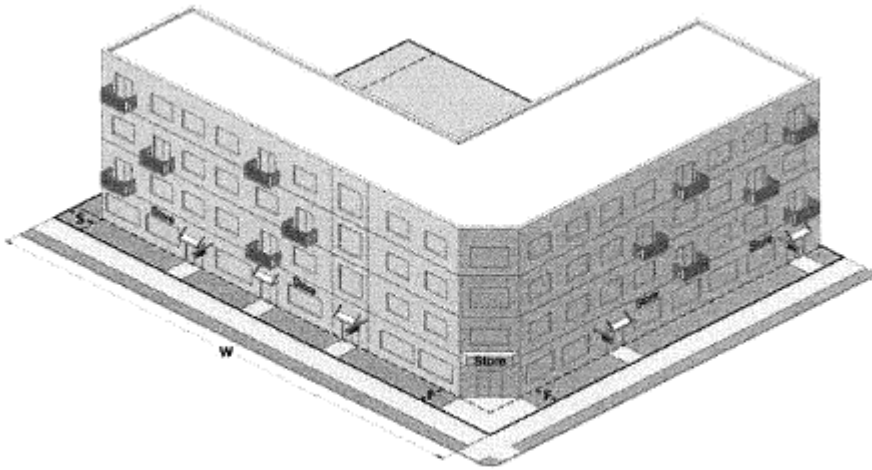

Vertical Mixed Use Multi-Story Form



Modern Materials



Traditional Materials

C. Building Form Standards:

1. The provisions of this section shall apply to all properties located within the Form Based Districts as indicated on the maps in each Form Based District.
2. Building form and street type standards apply to all new buildings and additions when the new construction related to the addition is greater than 25% of the footprint of the structure or 1,000 square feet, whichever is less. Refer to Section 21A.27.030 of this chapter on the building configuration standards for more information on how to comply with the standards. The graphics included provide a visual representation of the standards as a guide and are not meant to supersede the standards in the tables. Only building forms identified in the table are permitted.

SECTION 3. Amending the Text of Section 21A.27.030. That Section 21A.27.030 of the *Salt Lake City Code* (Zoning: Form Based Districts: Building Configuration and Design Standards), shall be and hereby is amended to read as follows:

**21A.27.030: BUILDING CONFIGURATION AND DESIGN STANDARDS:**

A. Specific Intent of Configuration and Design Standards:

1. Design Related Standards: The design related standards are intended to do the following:

- a. Implement applicable master plans;
- b. Continue the existing physical character of residential streets while allowing an increase in building scale along arterials and near transit stations;
- c. Focus development and future growth in the city along arterials and near transit stations;
- d. Arrange buildings so they are oriented toward the street in a manner that promotes pedestrian activity, safety, and community;
- e. Provide human scaled buildings that emphasize design and placement of the main entrance/exit on street facing facades;
- f. Provide connections to transit through public walkways;
- g. Provide areas for appropriate land uses that encourage use of public transit and are compatible with the neighborhood;
- h. Promote pedestrian and bicycle amenities near transit facilities to maximize alternative forms of transportation; and
- i. Rehabilitate and reuse existing residential structures in the Form Based Zoning Districts when possible to efficiently use infrastructure and natural resources, and preserve neighborhood character.

B. Building Entry: Refer to the building entrance standards in Subsection 21A.37.050.D of this title.

1. Entry Feature: The following building entries are permitted as indicated:

TABLE 21A.27.030.B  
ENTRY FEATURE STANDARDS

Entry Feature Permitted Based on Building Form Type	Urban House	Cottage Development	Two-Family Dwelling	Row House	Multi-Family	Storefront	Vertical Mixed Use
Porch and fence: A planted front yard where the street facing building facade is set back from the front property line with an attached porch that is	P	P	P	P	P		P

permitted to encroach into the required yard. The porch shall be a minimum of 6' in depth. The front yard may include a fence no taller than 3' in height							
---	--	--	--	--	--	--	--

Reference Illustration - Porch and Fence

Reference Illustration - Porch And Fence

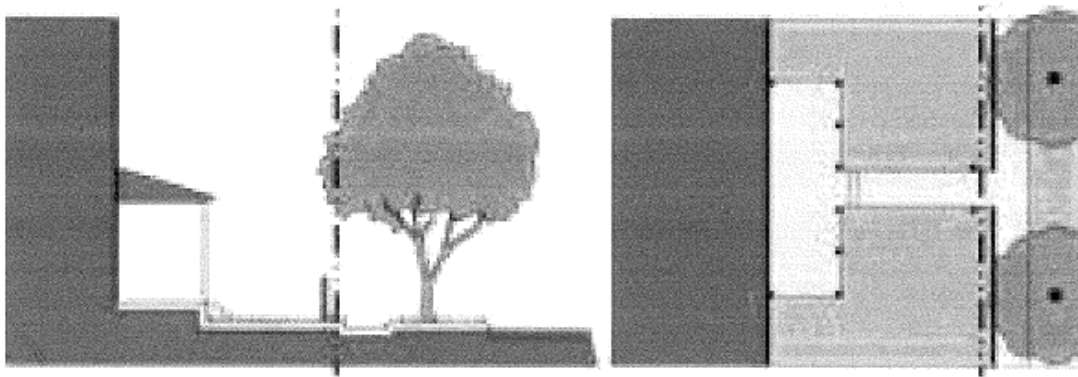

Entry Feature Permitted Based on Building Form Type	Urban House	Cottage Development	Two-Family Dwelling	Row House	Multi-Family	Storefront	Vertical Mixed Use
Terrace or lightwell: An entry feature where the street facing facade is set back from the front property line by an elevated	P	P	P	P	P	P	P

terrace or sunken lightwell. May include a canopy or roof							
---	--	--	--	--	--	--	--

Reference Illustration - Terrace or Lightwell

Reference Illustration - Terrace Or Lightwell

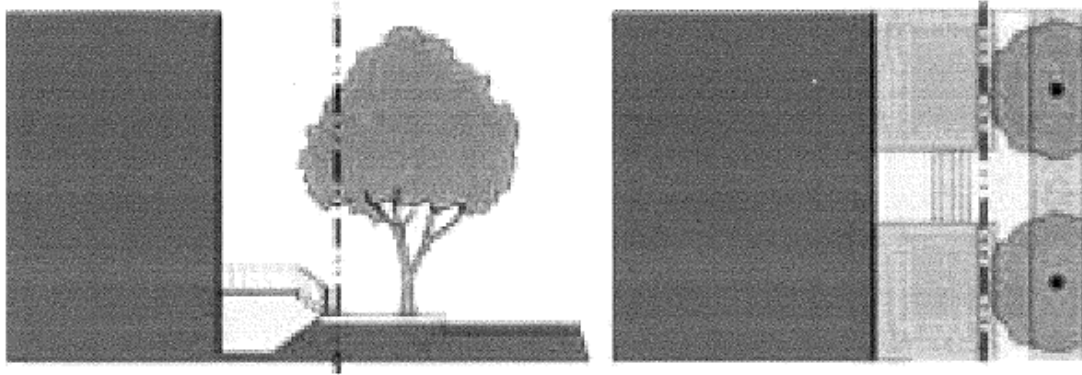

Entry Feature Permitted Based on Building Form Type	Urban House	Cottage Development	Two-Family Dwelling	Row House	Multi-Family	Storefront	Vertical Mixed Use
Forecourt: An entry feature wherein a portion of the street facing facade is close to the property line and the central portion is set back. The court created must be landscaped, contain outdoor plazas, outdoor dining areas,	P	P	P	P	P	P	P

private yards, or other similar features that encourage use and seating							
---	--	--	--	--	--	--	--

Reference Illustration - Forecourt

Reference Illustration - Forecourt

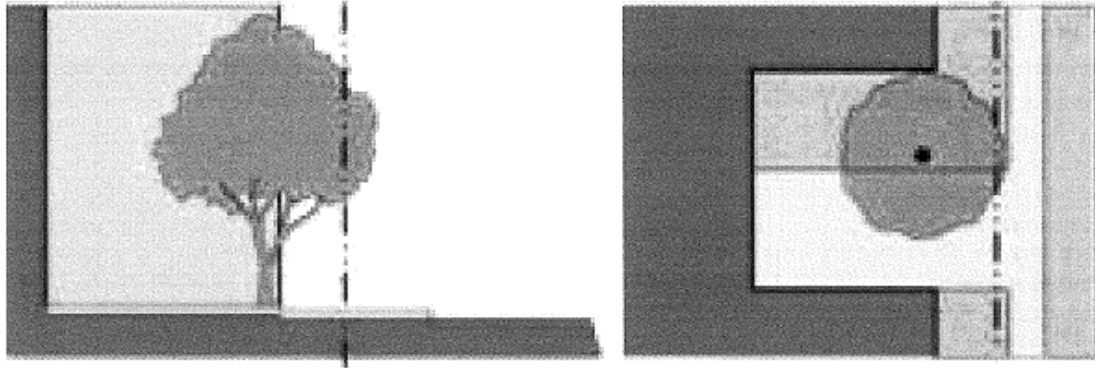

Entry Feature Permitted Based on Building Form Type	Urban House	Cottage Development	Two-Family Dwelling	Row House	Multi-Family	Storefront	Vertical Mixed Use
Stoop: An entry feature wherein the street facing facade is close to the front property line and the first story is elevated from the sidewalk sufficiently to secure privacy for the windows. The entrance contains an exterior stair and landing that is either parallel or	P	P	P	P	P	P	P



perpendicular to the street. Recommended for ground floor residential uses							
---	--	--	--	--	--	--	--

Reference Illustration - Stoop

Reference Illustration - Stoop

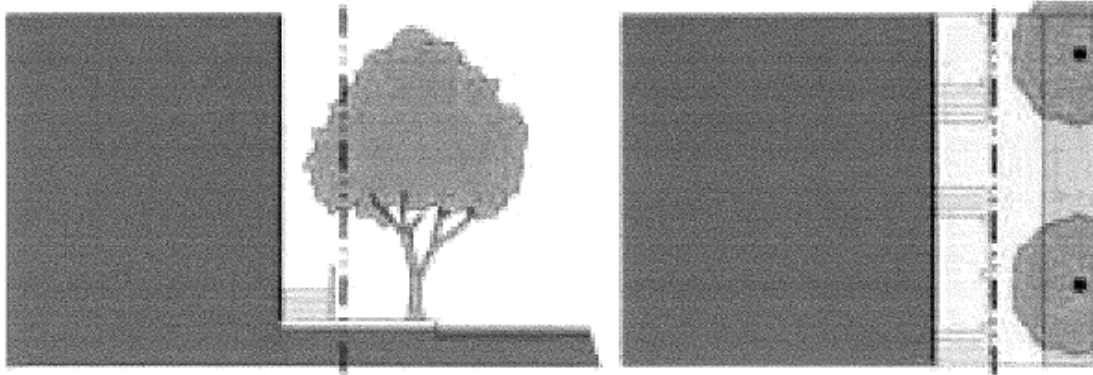

Entry Feature Permitted Based on Building Form Type	Urban House	Cottage Development	Two-Family Dwelling	Row House	Multi-Family	Storefront	Vertical Mixed Use
Shopfront: An entry feature where the street facing facade is close to the property line and building entrance is at sidewalk grade. Building entry is covered with an awning, canopy, or is recessed from the front building facade, which defines the entry and			P		P	P	P

provides protection for customers							
-----------------------------------	--	--	--	--	--	--	--

Reference Illustration - Shopfront

Reference Illustration - Shopfront

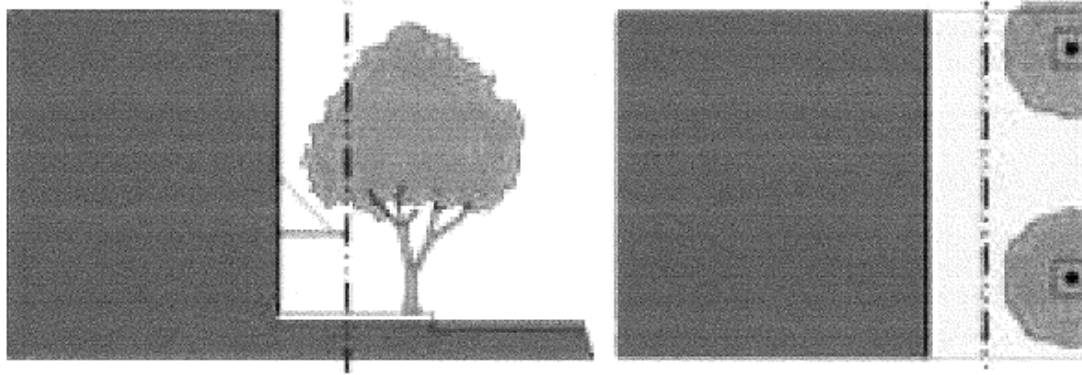

Entry Feature Permitted Based on Building Form Type	Urban House	Cottage Development	Two-Family Dwelling	Row House	Multi-Family	Storefront	Vertical Mixed Use
Gallery: A building entry where the ground floor is no more than 10' from the front property line and the upper levels or roofline cantilevers from the ground floor facade up to the front property line					P	P	P

Reference Illustration - Gallery

Reference Illustration - Gallery

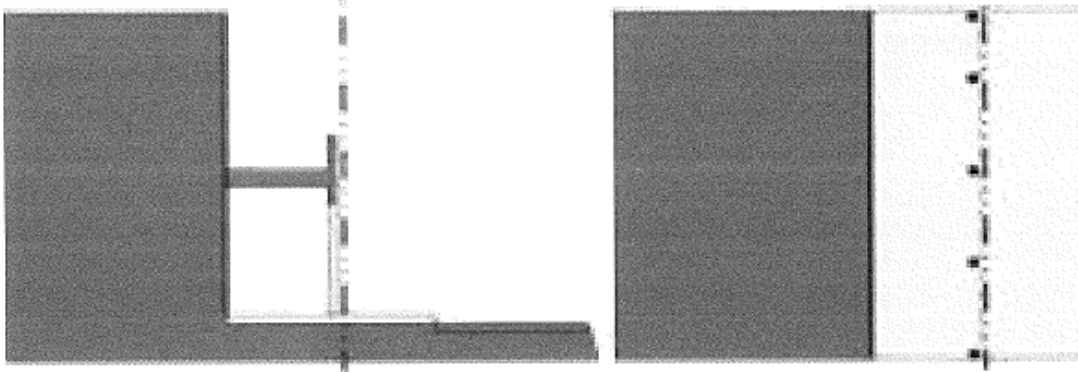

C. Additional Design Standards Required for Form Based Districts:

1. Open Space Area: A minimum of 10% of the lot area shall be provided for open space area, unless a different requirement is specified in the building form regulation. Individual districts may require additional open space area requirements. Open space area may include landscaped yards, patio, dining areas, common balconies, rooftop gardens, and other similar outdoor living spaces. Private balconies shall not be counted toward the minimum open space area requirement. Required parking lot landscaping or perimeter parking lot landscaping shall also not count toward the minimum open space area requirement.
  - a. At least one open space area shall include a minimum dimension of at least 15' by 15'.
  - b. Open space areas that are greater than 500 square feet must contain at least one useable element, accessible to all building occupants, from the following list.
    - i. A bench for every 250 square feet of open space area;
    - ii. A table for outdoor eating for every 500 square feet of open space area;
    - iii. An outdoor amenity. This is defined as an amenity that intends to provide outdoor recreation and leisure opportunities including, but not limited to, walking paths, playgrounds, seating areas, gardens, sport court or similar amenity intended to promote outdoor activity;
    - iv. Trees with a minimum spread of 20' at mature height to shade a minimum of 33% of the open space area; and/or
    - v. landscaping that equals at least 33% of the landscaped area.

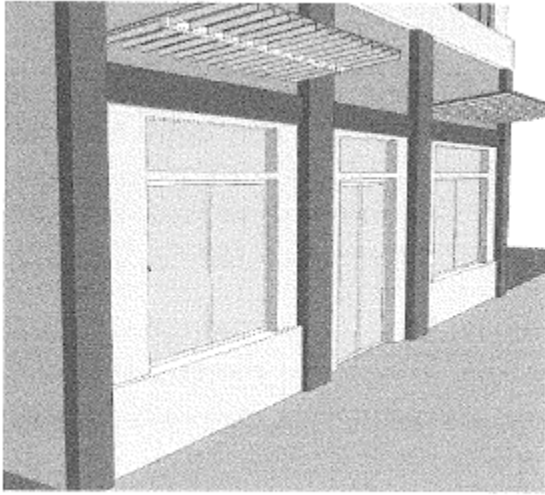

### Illustration Of Building Fenestration

2. Residential Balconies: All street facing residential units above the ground floor or level shall contain a usable balcony facing the street that is a minimum of four feet in depth. Balconies may overhang any required yard.
3. Design Standards Alternatives:
  - a. Alternatives to Required Build-To Line: Where a “required build-to” standard applies, the following alternatives may count toward the minimum build-to requirement as indicated:
    - (1) Landscaping Walls: Landscaping walls between 24” and 42” high may count up to 25% toward the minimum requirement provided the following:
      - (A) The wall incorporates seating areas.
      - (B) The wall is constructed of masonry, concrete, stone or ornamental metal.
      - (C) The wall maintains clear view sightlines where sidewalks and pedestrian connections intersect vehicle drive aisles or streets.
    - (2) Pergolas and Trellises: Pergolas and trellises may count up to 25% toward the minimum build-to requirement provided the following:
      - (A) The structure is at least 48” deep as measured perpendicular to the property line.
      - (B) A vertical clearance of at least eight feet is maintained above the walking path of pedestrians.
      - (C) Vertical supports are constructed of wood, stone, concrete or metal with a minimum of six inches by six inches or a radius of at least four inches.

- (D) The structure maintains clear view sightlines where sidewalks and pedestrian connections intersect vehicle drive aisles or streets.
- (3) Arcades: Arcades may count up to 100% toward the minimum requirement provided the following:
- (A) The arcade extends no more than two stories in height.
  - (B) No portion of the arcade structure encroaches onto public property.
  - (C) The arcade maintains a minimum pedestrian walkway of five feet.
  - (D) The interior wall of the arcade complies with the building configuration standards.
- (4) Plazas and Outdoor Dining: Plazas and outdoor dining areas may count up to 50% toward the minimum requirement, and have a maximum front setback of up to 15' provided the following:
- (A) The plaza or outdoor dining is between the property line adjacent to the street and the street facing building facade.
  - (B) Shall be within two feet of grade with the public sidewalk.
  - (C) The building entry shall be clearly visible through the courtyard or plaza.
  - (D) The building facades along the courtyard or plaza shall comply with the ground floor transparency requirement.
- b. Alternatives to Ground Floor Transparency Requirement: The planning director may modify the ground floor transparency requirement in the following instances:
- (1) The requirement would negatively impact the historical character of a building within the H Historic Preservation Overlay District; or
  - (2) The requirement conflicts with the structural integrity of the building and the structure would comply with the standard to the extent possible.
4. Permitted Encroachments and Height Exceptions: Obstructions and height exceptions are permitted as listed in this section or in Section 21A.36.020 of this title or as indicated in this subsection.
- a. Building Height: In order to promote a varied skyline and other roof shapes in the area, structures with a sloped roof may exceed the maximum building height in the form based districts by five feet provided:
- (1) The additional height does not include additional living space. Vaulted ceilings, storage spaces, and utility spaces are permitted.

- (2) The slope of the roof is a minimum of a twelve-four pitch or a quarter barrel shape.

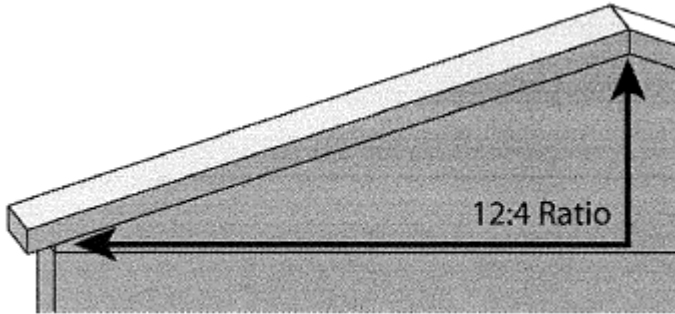

Minimum Slope Of Pitched Roof

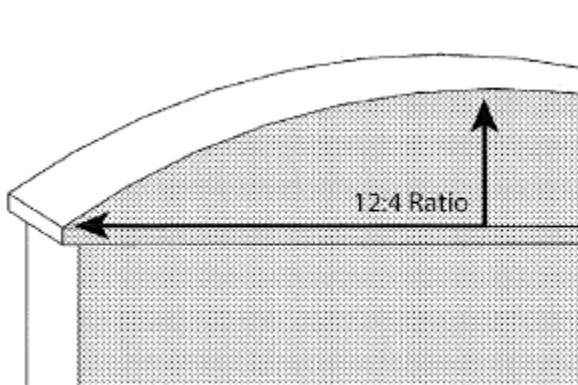

Minimum Slope Of Quarter Barrel Roof

- b. Roof Top Gardens: Building height encroachments for rooftop uses are permitted to encroach up to 6 feet to accommodate rooftop gardens and/or outdoor living space provided:
- (1) The rooftop garden includes vegetation that covers a minimum of 15% of the outdoor living space on the roof. The vegetation coverage shall be calculated by utilizing the spread of any trees, shrubs, or ground cover at maturity.
  - (2) If the rooftop is used for non-residential land uses allowed in the zone and located adjacent to the FB-UN1 Form Based Urban Neighborhood District, single-family district, or two-family district, a six foot wall shall be installed along the entire length of the outdoor space facing such zones.

5. Pedestrian Connections: Where required, the following pedestrian connection standards apply:
  - a. The connection shall provide direct access from any building entry to the public sidewalk or walkway.
  - b. The connection shall comply with the Americans With Disabilities Act (ADA) standards for accessibility.
  - c. The connection shall be fully paved and have a minimum width of four feet (4').
  - d. The connection shall be separated from vehicle drive approaches and drive lanes by a change in grade and a wheel stop if the walkway is less than eight feet (8') wide.
  - e. Pedestrian connections that lead directly from the sidewalk to the primary building entrance may contain wing walls, no taller than two feet (2') in height for seating, landscaping, etc.

D. Other Applicable Development Standards: All uses in the form based districts shall comply with the standards set in Part IV, Regulations of General Applicability, of this title, including the applicable standards in the following chapters:

1. 21A.33 Land Use Tables
2. 21A.36 General Provisions
3. 21A.37 Design Standards
4. 21A.38 Nonconforming Uses and Noncomplying Structures
5. 21A.40 Accessory Uses, Buildings, and Structures
6. 21A.42 Temporary Uses
7. 21A.44 Off Street Parking, Mobility, and Loading
8. 21A.46 Signs
9. 21A.48 Landscaping and Buffers
10. Any other applicable chapter of this title that may include applicable provisions.

E. Form Based Special Purpose Corridor District specific standards for detached or accessory parking garages or structures:

1. Detached or accessory multilevel parking garages or structures shall have the same setback requirements for principal structures.
2. When a required setback abuts a residential district, the minimum setback required shall be a landscape yard to provide a buffer to the abutting residential district. No structure (primary or accessory) shall be permitted within this landscaped buffer.

SECTION 4. Amending the Text of Subsection 21A.27.050.C. That Subsection 21A.27.050.C of the *Salt Lake City Code* (Zoning: Form Based Districts: FB-UN1 and FB-UN2 Form Based Urban Neighborhood District: FB-UN2 Building Form Standards), shall be and hereby is amended to read as follows:

C. FB-UN2 Building Form Standards: Building form standards are listed in Tables 21A.27.050.C.1 through 21A.27.050.C.3 of this section.

**1. Cottage Development Form Standards:  
TABLE 21A.27.050.C.1**

<b>Building Regulation</b>		<b>Regulation for Building Form: Cottage Development</b>
<b>H</b>	<b>Height</b>	30' maximum. All heights measured from the established grade.
<b>F</b>	<b>Front and Corner Side Yard Setback</b>	Minimum 10'. Provided front or corner side yard shall provide one tree for every 30 linear foot of front or corner side yard property line. The mature tree canopy must cover at least 50% of the required yard area and sidewalk area.
<b>S</b>	<b>Interior Side Yard</b>	Minimum of 6'.
<b>R</b>	<b>Rear Yard</b>	Minimum of 20' between cottage building form and rear property line.
<b>SC</b>	<b>Separation between Cottages</b>	Minimum of 10', measured from the outside perimeter wall of the principal structure.
<b>E</b>	<b>Entry Feature</b>	Each dwelling unit must include an allowed entry feature. See Table 21A.27.030.B for allowed entry features. Dwelling units adjacent to a street must include an entry feature on the street facing façade. Pedestrian connections with minimum of 5' width required to each required entry feature.
<b>OS</b>	<b>Open space Area</b>	At least 25% of the total land area of the cottage development shall be maintained as an open space area that complies with the requirements of Subsection 21A.27.030.C.1 "Open Space Area."



<b>BF</b>	<b>Building forms per lot</b>	Multiple buildings may be built on a single lot. Individual lots without street frontage may be created provided each lot has legally established access to a public street that includes a minimum 5’ wide solid surface walkway.
<b>SO</b>	<b>Side/Interior Orientation</b>	Dwelling units not located directly adjacent to a street are permitted, provided the design standards for glass are complied with on the façade with the required entry feature.
<b>L</b>	<b>Lots without Street Frontage</b>	Lots for individual cottage units without public street frontage are allowed subject to recording a final subdivision plat that: 1. Documents that new lots have adequate access for pedestrians and vehicles to a public street by way of a minimum 5’ wide solid surface walkway, easements or a shared driveway; and 2. Includes a disclosure of private infrastructure costs for any shared infrastructure associated with the new lot(s). The requirements for the disclosure of private infrastructure costs shall be the same as required for planned developments per Section 21A.55.110 of this title.
<b>MW</b>	<b>Midblock Walkway</b>	As part of the city’s plan for the downtown area, it is intended that midblock walkways be provided to increase pedestrian connectivity and overall livability downtown through the creation of an intricate pedestrian network. The city has adopted the Downtown Plan that includes a midblock walkway map and establishes the need for such walkways as the Downtown grows. Because the districts within the downtown area allow building heights that exceed those of other districts in the city, the requirement for a midblock walkway is considered to be necessary to alleviate pedestrian impacts on the public sidewalks by dispersing future use of the public sidewalks. All buildings constructed after the effective date hereof within this district shall conform to this officially adopted plan for midblock walkways, in addition to the following standards:  F. The midblock walkway must be a minimum of 15’ wide and include a minimum 6’ wide unobstructed path. G. The midblock walkway may be incorporated into the building provided it is open to the public. A sign shall be posted indicating that the public may use the walkway. H. Building encroachments into the midblock walkway are permitted if they include one or more of the following elements: (1) Colonnades; (2) Staircases; (3) Balconies – All balconies must be located at the third story or above.

		<p>(4) Building overhangs and associated cantilever – These coverings may be between 9 and 14 feet above the level of the sidewalk. They shall provide a minimum depth of coverage of 6’ and project no closer to the curb than 3’.</p> <p>(5) Skybridge – A single skybridge is permitted. All skybridges must be located at the 3<sup>rd</sup>, 4<sup>th</sup>, or 5<sup>th</sup> stories.</p> <p>(6) Other architectural element(s) not listed above that offers refuge from weather and/or provide publicly accessible usable space.</p>
<b>DS</b>	<b>Design Standards</b>	See Section 21A.27.030 and Chapter 21A.37 for other applicable building configuration and design standards.

**2. Row House Building Form Standards:  
TABLE 21A.27.050.C.2**

<b>Building Regulation</b>		<b>Regulation for Building Form: Row House</b>
<b>H</b>	<b>Height</b>	Maximum of 40'; All heights measured from established grade. Rooftop decks and associated railing/parapet are allowed on any roof, including roofs at the maximum allowed height. The height of the railing/parapet is limited to the height required to meet building code requirements.
<b>F</b>	<b>Front and Corner Side Yard Setback</b>	Minimum 10' and maximum 15', unless a greater setback is required due to existing utility easements in which case the maximum setback shall be at the edge of the easement. This requirement may be modified through Design Review (Chapter 21A.59). Provided front or corner side yard shall provide one tree for every 30 linear foot of front or corner side yard property line. The mature tree canopy must cover at least 50% of the required yard area and sidewalk area.
<b>S</b>	<b>Interior Side Yard</b>	Minimum of 6' between row house building form and side property line. Minimum of 10' along a side property line when abutting a property in a zoning district with a maximum permitted building height of 35' or less. No setback is required for common walls.
<b>R</b>	<b>Rear Yard</b>	Minimum of 20' between row house building form and rear property line, except when rear yard is abutting a zoning district with a maximum permitted building height of 35' or less, then the minimum is 25'. For the purpose of this regulation, an alley that is a minimum of 10' in width that separates the subject property from another property shall be counted towards the minimum setback.
<b>U</b>	<b>Uses Per Story</b>	Residential on all stories; live/work units permitted on ground level.
<b>E</b>	<b>Entry Feature</b>	Each dwelling unit must include an allowed entry feature. See Table 21A.27.030.B for allowed entry features. Dwelling units adjacent to a street must include an entry feature on street facing façade. Pedestrian connections with minimum 5' width required to each required entry feature.
<b>U</b>	<b>Upper level Stepback</b>	When adjacent to a lot in a zoning district with a maximum building height of 35' or less, the first full floor of the building above 30', measured from finished grade, shall stepback 10' from the building facade along the side or rear yard that is adjacent to the lot in the applicable zoning district. This regulation does not apply when a lot in a different zoning district is separated from the subject parcel by a street or alley.

<b>OS</b>	<b>Open space Area</b>	Each dwelling unit shall include a minimum open space area that is equal to at least 25% of the footprint of the individual unit, subject to all other open space area requirements of Subsection 21A.27.030.C.1 “Open Space Area.” A minimum of 20% of the required open space area shall include vegetation. Tree canopy at maturity shall count toward the vegetation requirement,
<b>BF</b>	<b>Building Forms per Lot</b>	Multiple buildings may be built on a single lot provided all of the buildings have frontage on a street. All buildings shall comply with all applicable standards.
<b>SO</b>	<b>Side/Interior Orientation</b>	Dwelling units not located directly adjacent to a street are permitted, provided the design standards for glass are complied with on the façade with the required entry feature. Lots for individual row house dwelling units without public street frontage are allowed subject to recording a final subdivision plat that: <ol style="list-style-type: none"> <li>1. Documents that new lots have adequate access to a public street by way of easements or a shared driveway; and</li> <li>2. Includes a disclosure of private infrastructure costs for any shared infrastructure associated with the new lot(s) per Section 21A.55.110 of this title.</li> </ol>
<b>MW</b>	<b>Midblock Walkway</b>	As part of the city’s plan for the downtown area, it is intended that midblock walkways be provided to facilitate pedestrian movement within the area. The city has adopted the Downtown Plan that includes a midblock walkway map and establishes a need for such walkways as the Downtown grows. Because the districts within the downtown area allow maximum building heights that exceeds those of other districts in the city, the requirement for the midblock walkway is important to maintain the overall scale and pedestrian nature of the downtown. This requirement implements the city’s Downtown Plan and provides visual relief from the additional height that is available in these zone districts when compared to the remainder of the city. All buildings constructed after the effective date hereof within the Downtown zoning districts shall conform to this officially adopted plan for midblock walkways, in addition to the following standards: <ol style="list-style-type: none"> <li>a. Any new development shall provide a midblock walkway if a midblock walkway on the subject property has been identified in a master plan that has been adopted by the city.</li> <li>b. The midblock walkway may be incorporated into the building provided it is open to the public. A sign shall be posted indicating that the public may use the walkway.</li> </ol> <p style="margin-left: 40px;">The following building encroachments are permitted in a midblock walkway. Under no circumstances shall a midblock walkway be entirely covered.</p>

		<ul style="list-style-type: none"> <li>(1) Colonnades;</li> <li>(2) Staircases;</li> <li>(3) Balconies: All balconies must be located at the third story or above;</li> <li>(4) Building overhangs and associated cantilever: These coverings may be between nine and fourteen feet above the level of the sidewalk. They shall provide a minimum depth of coverage of six feet and project no closer to the curb than three feet;</li> <li>(5) Skybridge: A single skybridge is permitted. All skybridges must be located at the third, fourth, or fifth stories; and</li> <li>(6) Other architectural element(s) not listed above that offers refuge from weather and/or provide publicly accessible usable space.</li> </ul>
<b>DS</b>	<b>Design Standards</b>	See Section 21A.27.030 and Chapter 21A.37 for other applicable building configuration and design standards.

**3. Multi-family Residential, Storefront, and Vertical Mixed-use building form standards:**

**TABLE 21A.27.050.C.3**

<b>Building Regulation</b>		<b>Regulation for Building Forms: Multi-family Residential/Storefront/Vertical Mixed Use</b>
<b>H</b>	<b>Height</b>	Maximum height of 50'. <sup>1</sup> All heights measured from established grade. Rooftop use is permitted and required railings and walls necessary to comply with building code requirements are permitted to encroach beyond the maximum height up to 5'.
<b>GH</b>	<b>Ground Floor Height</b>	Minimum ground floor height of 14'.
<b>F</b>	<b>Front and Corner Side Yard Setback</b>	Ground Floor Residential Uses: A minimum of 10' and a maximum of 20'. Ground Floor occupied by retail, restaurants, taverns, brewpubs, bar establishments, art galleries, theaters, or performing art facilities: no minimum is required, provided no doors open into the right of way. A maximum setback of up to 10' is allowed. All other ground floor uses: A minimum of 5' and a maximum 10'. The maximum may be increased due to existing utility easements in which case the maximum setback shall be at the edge of the easement.

		<p>This requirement may be modified through Design Review process (Chapter 21A.59).</p> <p>Provided front or corner side yard shall provide one tree for every 30 linear foot of front or corner side yard property line. The mature tree canopy must cover at least 50% of the required yard area and sidewalk area.</p>
<b>S</b>	<b>Interior Side Yard</b>	<p>Minimum of 6' required, except when an interior side yard is abutting a property in a zoning district with a maximum permitted building height of 35' or less, then the minimum shall be 15'. For the purpose of this regulation, an alley that is a minimum of 10' in width that separates a subject property from a different zoning district shall be counted towards the minimum setback.</p>
<b>R</b>	<b>Rear Yard</b>	<p>The rear yard minimum shall be 10', except when rear yard is adjacent to a zoning district with a maximum permitted building height of 30' or less, then the minimum is 20'. For the purpose of this regulation, an alley that is a minimum of 10' in width that separates a subject property from a property in a different zoning district shall be counted towards the minimum setback.</p>
<b>GU</b>	<b>Ground Floor Use Requirements</b>	<p>900 South: The ground floor use space facing 900 South shall be limited to the following uses: retail goods establishments, retail service establishments, public service portions of businesses, restaurants, taverns/brewpubs, bar establishments, art galleries, theaters, or performing art facilities for a depth of 25'. Amenity space for the occupants of the building shall account for no more than 25% of the length of the ground floor space.</p>
<b>E</b>	<b>Ground Floor Dwelling Entrances</b>	<p>Ground floor dwelling units adjacent to a street must have an allowed entry feature. See Table 21A.27.030.B for allowed entry features.</p>
<b>U</b>	<b>Upper Level Stepback</b>	<p>When adjacent to a lot in a zoning district with a maximum building height of 30' or less, the first full floor of the building above 30' shall stepback 10' from the building facade at finished grade along the side or rear yard that is adjacent to the lot in the applicable zoning district. This regulation does not apply when a lot in a different zoning district is separated from the subject parcel by a street or alley</p>
<b>M W</b>	<b>Midblock Walkway</b>	<p>As part of the city's plan for the downtown area, it is intended that midblock walkways be provided to facilitate pedestrian movement within the area. The city has adopted the Downtown Plan that includes a midblock walkway map and establishes a need for such walkways as the Downtown grows. Because the districts within the downtown area allow</p>

		<p>maximum building heights that exceeds those of other districts in the city, the requirement for the midblock walkway is important to maintain the overall scale and pedestrian nature of the downtown. This requirement implements the city’s Downtown Plan and provides visual relief from the additional height that is available in these zone districts when compared to the remainder of the city. All buildings constructed after the effective date hereof within this district shall conform to this officially adopted plan for midblock walkways, in addition to the following standards:</p> <ol style="list-style-type: none"> <li>1. Any new development shall provide a midblock walkway if a midblock walkway on the subject property has been identified in a master plan that has been adopted by the city.</li> <li>2. The following standards apply to the midblock walkway: <ol style="list-style-type: none"> <li>a. The midblock walkway must be a minimum of 15’ wide and include a minimum 6’ wide unobstructed path.</li> <li>b. The midblock walkway may be incorporated into the building provided it is open to the public. A sign shall be posted indicating that the public may use the walkway.</li> <li>c. The following building encroachments are permitted in midblock walkway. Under no circumstances shall a mid block walkway be entirely covered. <ol style="list-style-type: none"> <li>(1) Colonnades;</li> <li>(2) Staircases;</li> <li>(3) Balconies – All balconies must be located at the third story or above;</li> <li>(4) Building overhangs and associated cantilever - These coverings may be between 9 and 14’ above the level of the sidewalk. They shall provide a minimum depth of coverage of 6’ and project no closer to the curb than 3’;</li> <li>(5) Skybridge – A single skybridge is permitted. All skybridges must be located at the third, fourth, or fifth stories; and</li> <li>(6) Other architectural element(s) not listed above that offers refuge from weather and/or provide publicly accessible usable space.</li> </ol> </li> </ol> </li> </ol>
<b>BF</b>	<b>Building Forms Per Lot</b>	Multiple buildings may be built on a single lot provided all of the buildings have frontage on a street. All buildings shall comply with all applicable standards.
<b>OS</b>	<b>Open Space Area</b>	As required in Subsection 21A.27.030.C.1 “Open Space Area.”

<b>DS</b>	<b>Design Standards</b>	See Section 21A.27.030 and Chapter 21A.37 for other applicable building configuration and design standards.
-----------	-------------------------	---

**Footnotes:**

1. Additional Building Height Regulations. Properties listed in this footnote shall have a permitted building height of up to 65’ and 5 stories.
  - a. For legally existing parcels or lots as of January 1, 2023 located on the corners of West Temple at 800 South or 900 South;
  - b. For legally existing parcels or lots as of January 1, 2023 located on the corners of 200 West at 700 South, 800 South or 900 South;
  - c. For legally existing parcels or lots as of January 1, 2023 located on the corners of West Temple at Fayette Avenue;
  - d. For legally existing parcels or lots as of January 1, 2023 located on the corners of 300 West at 800 South or 900 South;
  - e. On the southeast corner of 1300 South and State Street.
  - f. As indicated on the following map:



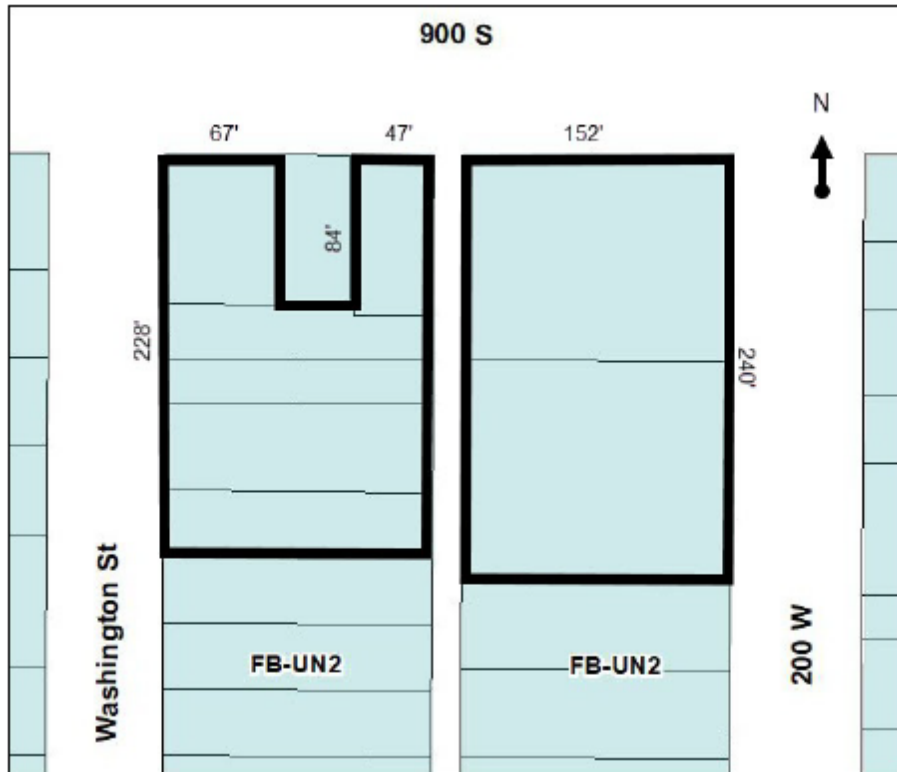

SECTION 5. Amending the Text of Chapter 21A.30. That Chapter 21A.30 of the *Salt Lake City Code* (Zoning: Downtown Districts), shall be and hereby is amended to read as follows:

CHAPTER 21A.30  
DOWNTOWN DISTRICTS

SECTION:

- 21A.30.010: General Provisions**
- 21A.30.020: D-1 Central Business District**
- 21A.30.030: D-2 Downtown Support District**
- 21A.30.040: D-3 Downtown Warehouse/Residential District**
- 21A.30.045: D-4 Downtown Secondary Central Business District**

**21A.30.010: GENERAL PROVISIONS:**

- A. Statement of Intent: The downtown districts are intended to provide use, bulk, urban design and other controls and regulations appropriate to the commercial core of the city and adjacent areas in order to enhance employment opportunities; to encourage the efficient use of land; to enhance property values; to improve the design quality of downtown areas; to create a unique downtown center which fosters the arts, entertainment, financial, office, retail and governmental activities; to provide safety and security; encourage permitted residential uses within the downtown area; and to help implement adopted plans.
- B. Permitted Uses: The uses specified as permitted uses in Section 21A.33.050, “Table of Permitted and Conditional Uses for Downtown Districts”, of this title are permitted; provided, that they comply with all requirements of this chapter, the general standards set forth in Part IV of this title, and all other applicable requirements of this title.
  - 1. Conditional Uses: The uses specified as conditional uses in Section 21A.33.050, “Table of Permitted and Conditional Uses for Downtown Districts”, of this title, may be allowed in the downtown districts provided they are approved pursuant to the standards and procedures for conditional uses set forth in Chapter 21A.54 of this title, and comply with all other applicable requirements.
- C. Impact Controls and General Restrictions in the Downtown Districts:
  - 1. Refuse Control: Refuse containers must be covered and shall be stored within completely enclosed buildings or screened in conformance with the requirements of Chapter 21A.48 of this title. For buildings existing as of April 12, 1995, this screening provision shall be required if the floor area or parking requirements are increased by twenty five percent (25%) or more by an expansion to the building or change in the type of land use.
  - 2. Lighting: On site lighting, including parking lot lighting and illuminated signs, shall be located, directed or designed in such a manner so as not to create glare on adjacent properties.
- D. Outdoor Sales, Display and Storage: “Sales and display (outdoor)” and “storage and display (outdoor)”, as defined in Chapter 21A.62 of this title, are allowed where specifically authorized in Section 21A.33.050, “Table of Permitted and Conditional Uses for Downtown Districts”, of this title. These uses shall conform to the following:
  - 1. The outdoor sales or display of merchandise shall not encroach into areas of required parking for periods longer than 30 days;
  - 2. The outdoor sales or display of merchandise shall not be located in any required yard area within the lot when the required yard abuts a residential zoning district;
  - 3. The outdoor sales or display of merchandise shall not include the use of banners, pennants or strings of pennants;

4. Outdoor storage shall be allowed only where specifically authorized in the applicable district regulation and shall be required to be fully screened with opaque fencing not to exceed eight feet in height; and
  5. Outdoor sales and display and outdoor storage shall also be permitted when part of an authorized temporary use as established in Chapter 21A.42 of this title.
- E. Restrictions on Parking Lots and Structures: An excessive amount of at or above ground parking lots and structures can negatively impact the urban design objectives of the Downtown Zoning Districts. To control such impacts, the following regulations apply to surface parking and above grade structures:
1. Parking shall be located behind principal buildings or incorporated into the principal building provided the parking is wrapped on street facing facades with a use allowed in the zone other than parking.
  2. A parking lot shall not consist of more than two double-loaded parking aisles (bays) adjacent to each other. The length of a parking lot shall not exceed 10 stalls. Parking for government facilities necessary for public health and safety are exempt from this provision.

Illustration of Regulation 21A.010.E.2 Surface Parking Lots

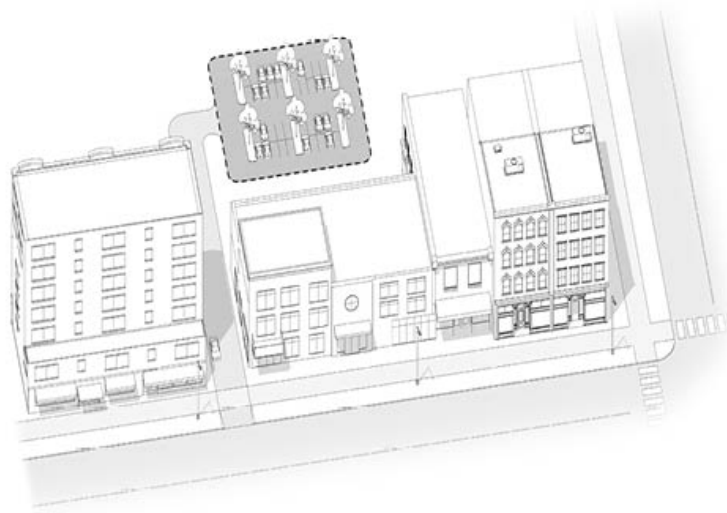

3. Parking lots, garages or parking structures, proposed as the only principal use on a property that has frontage on a public street and that would result in a building demolition are prohibited in the Downtown zoning districts.
4. No special restrictions shall apply to belowground parking facilities.

F. Midblock Walkways: As part of the city’s plan for the downtown area, it is intended that midblock walkways be provided to increase pedestrian connectivity and overall livability downtown through the creation of an intricate pedestrian network. The city has adopted the Downtown Plan that includes a midblock walkway map and establishes a need for such walkways as the Downtown grows. Because the districts within the downtown area allow building heights that exceed those of other districts in the city, the requirement for a midblock walkway is considered to be necessary to alleviate pedestrian impacts on the public sidewalks by dispersing future use of the public sidewalks. All buildings constructed after the effective date hereof within the Downtown zoning districts shall conform to this officially adopted plan for midblock walkways, in addition to the following standards:

1. Any new development shall provide a midblock walkway if a midblock walkway on the subject property has been identified in a master plan that has been adopted by the city.
2. The following standards apply to the midblock walkway:
  - a. The midblock walkway must be a minimum of 15’ wide and include a minimum 6’ wide unobstructed path.
  - b. The midblock walkway may be incorporated into the building provided it is open to the public. A sign shall be posted indicating that the public may use the walkway.
  - c. Building encroachments into the midblock walkway are permitted if they include one or more of the following elements:
    - (1) Colonnades;
    - (2) Staircases;
    - (3) Balconies: All balconies must be located at the third story or above.
    - (4) Building overhangs and associated cantilever - These coverings may be between 9 and 14’ above the level of the sidewalk. They shall provide a minimum depth of coverage of six feet and project no closer to the curb than three feet.
    - (5) Skybridge: A single skybridge is permitted. All skybridges must be located at the third, fourth, or fifth stories.
    - (6) Other architectural element(s) not listed above that offers refuge from weather and/or provide publicly accessible usable space.

Illustration of Regulation 21A.30.010.F Midblock Walkways

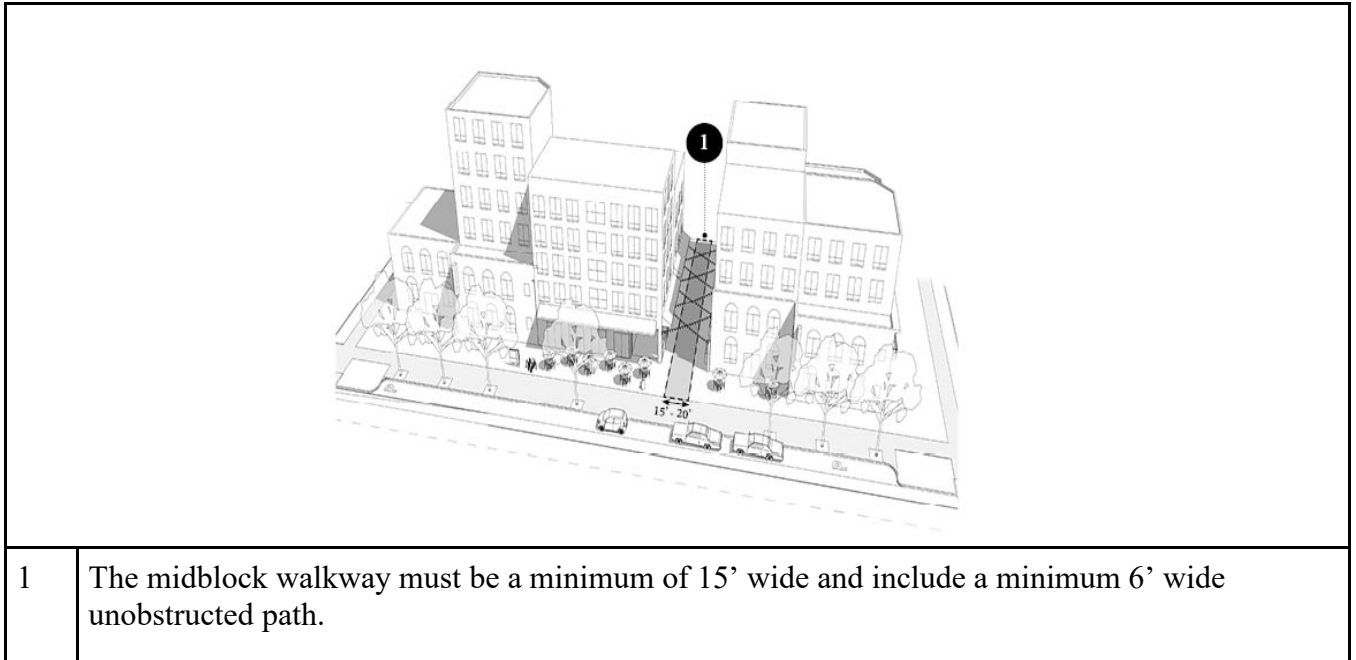

G. Sidewalks: For all downtown districts, sidewalks must be a clear walking path that is a minimum of 10' wide. Outdoor dining shall be permitted within the sidewalk if it complies with the minimum width of a clear path as defined in the outdoor dining design guidelines.

H. Additional Standards: All uses in the downtown districts shall comply with the standards set in Part IV, Regulations of General Applicability, of this title, including the applicable standards in the following chapters:

1. 21A.36 General Provisions
2. 21A.37 Design Standards
3. 21A.38 Nonconforming Uses and Noncomplying Structures
4. 21A.40 Accessory Uses, Buildings, and Structures
5. 21A.42 Temporary Uses
6. 21A.44 Off Street Parking, Mobility, and Loading
7. 21A.46 Signs
8. 21A.48 Landscaping and Buffers
9. Any other applicable chapter of this title that may include applicable provisions.

**21A.30.020: D-1 CENTRAL BUSINESS DISTRICT:**

A. Purpose Statement: The purpose of the D-1 Central Business District is to provide for commercial and economic development within Salt Lake City's most urban and intense areas. A broad range of uses, including very high density housing, are intended to foster a

24 hour activity environment consistent with the area's function as the business, office, retail, entertainment, cultural and tourist center of the region. Development is intended to be very intense with high lot coverage and large buildings that are placed close together while being oriented toward the pedestrian with a strong emphasis on a safe and attractive streetscape and preserving the urban nature of the downtown area. This district is appropriate in areas where supported by applicable master plans. The standards are intended to achieve established objectives for urban design, pedestrian amenities and land use control.

- B. Uses: Uses in the D-1 Central Business District as specified in Section 21A.33.050, "Table of Permitted and Conditional Uses for Downtown Districts", of this title, are permitted subject to the general provisions set forth in Section 21A.30.010 of this chapter.
- C. D-1 Central Business District General Regulations: The regulations established in this section apply to the D-1 Central Business District as a whole
  - 1. Yard Requirements: No minimum yards are required. A maximum yard of eight feet is allowed.
    - a. If provided, the yard must include one of the following elements:
      - i. Seating at a ratio of at least one bench for every 500 square feet of yard space; or
      - ii. Landscaping that includes an increase of at least 25% in the total number of trees required to be planted on the site; or
      - iii. Awning or a similar form of weather protection that covers at least five feet in width and length from all street-facing building entrances.
    - b. Exceptions to this requirement may be authorized through the design review process, subject to the requirements of Chapter 21A.59 of this title.
    - c. The planning director, in consultation with the transportation director, may modify this requirement to accommodate a wider sidewalk if the adjacent public sidewalk is less than 15' wide and the resulting modification to the setback results in a more efficient public sidewalk. The planning director may waive this requirement for any addition, expansions, or intensification, which increases the floor area or parking requirement by less than 50% if the planning director finds the following:
      - i. The architecture of the addition is compatible with the architecture of the original structure or the surrounding architecture, or
      - ii. The addition reduces the extent of the noncompliance of the existing building.

- d. Regardless of the setback provided, doors shall be setback a minimum distance to allow the door to operate without swinging into a right of way or midblock walkway.
  - e. Interior Side Yards: No minimum interior side yard is required.
  - f. Rear Yard: No minimum rear yard is required.
4. Landscape Requirements for Demolition Sites: Vacant lots, resulting from demolition activities where no replacement use is proposed, shall conform to Chapter 21A.48 of this title, special landscape requirements applicable to the D-1 Central Business District.
- D. Height Regulations: Buildings in the D-1 zoning district shall comply with the following provisions:
- 1. Building Heights: No building shall be less than 100'. There is no maximum building height, subject to standards contained in Subsections 21A.30.020.D.2 through D.3.
  - 2. Exceptions to the minimum height requirements are as follows:
    - a. Utility Buildings necessary to provide electricity, water, sewer, storm water, and other necessary utility services to the downtown area.
    - b. Accessory building and structures, including accessory buildings that serve public transportation, downtown improvement districts, and other public maintenance buildings.
    - c. Buildings on lots or parcels that are less than 5,000 square feet in size.
    - d. Buildings with a footprint of less than 2,500 square feet.
    - e. Building approved through the design review process in Chapter 21A.59.
  - 2. Buildings in excess of 100', are allowed subject to the following standard:
    - a. A minimum stepback of five feet or other architectural feature that can deflect snow and ice from falling directly onto a sidewalk, midblock walkway, or other public space. The stepback may be located above the height of the first floor and below 150' in height above the sidewalk or public space. Buildings that are not clad in glass are exempt from this requirement.
  - 3. Buildings in excess of 200' with no limit and subject to Chapter 21A.59, Design Review, shall include at least one of the following five options:
    - a. Midblock walkway is provided on the property and the midblock walkway connects to an existing or planned street, midblock walkway, or publicly accessible public space and exceeds all the required dimensions of Subsection 21A.30.010.G by at least five feet. This option allows for additional height in return for exceeding the midblock walkway requirements; or

- b. The building is utilizing affordable housing incentives identified in Chapter 21A.52 of this title; or
- c. The property where the building is located exceeds the minimum requirement for ground floor uses identified in chapter 21A.37 (Design Standards) of this title, specifically:
  - (1) For Subsection 21A.37.050.A.1 (Design Standards Defined, Ground Floor Use Only), the requirement must be increased to 100%. This option requires that the entire ground floor use of a building consists of retail good establishments, retail service establishments or restaurants, public service portions of businesses, department stores, art galleries, motion picture theaters, performing art facilities or similar uses that encourages walk-in traffic through an active use. Vehicle entry and exit ways necessary for access to parking are exempt from this requirement; or
  - (2) For Subsection 21A.37.050.A.2 (Design Standards Defined, Ground Floor Use and Visual Interest), the ground floor use requirement must be increased to 85% and the visual interest requirement must be increased to 15%. This option requires an increased percentage of ground floor space to be used for an active use, and an increased percentage of the building to provide visual interest;
- d. The applicant provides a restrictive covenant on a historic building, a building that is 50 years or older, or a building that is a nationally recognized property, located outside of the H Historic Preservation Overlay District for the purpose of preserving the structure for a minimum of 50 years.
- e. The proposal includes a privately owned, publicly accessible open space on the property or on another property within the geographic boundaries of the Downtown Plan. To qualify for this provision, a restrictive covenant in the favor of the city shall be recorded against the open space portion of the property. The space shall be a minimum of 500 square feet and include enough trees to provide a shade canopy that covers at least 60% of the open space area. This option allows for additional height in return for the designation of open public open space.

E. Special Controls Over the Main Street Retail Core:

- 1. Intent: Special controls shall apply to land located within the Main Street retail core area to preserve and enhance the viability of retail uses within the downtown area. The regulations of this subsection shall be in addition to the requirements of Subsections C and D of this section.
- 2. Area of Applicability: The controls established in this subsection shall apply to property developed or redeveloped after April 12, 1995, when located along any block face on the following streets:
  - a. Main Street located within the D-1 District;



- b. 100 South Street between West Temple Street and State Street;
  - c. 200 South Street between West Temple Street and State Street; and
  - d. 300 South Street between West Temple Street and State Street.
3. First Floor Retail Required: The first floor space of all buildings within this area shall be required to provide uses consisting of retail goods establishments, retail service establishments or restaurants, public service portions of businesses, department stores, art galleries, motion picture theaters or performing arts facilities.
4. Restrictions on Driveways: Driveways shall not be permitted along Main Street, but shall be permitted along other streets within the Main Street retail core area, provided they are located at least 80' from the intersection of two street right of way lines.

**21A.30.030: D-2 DOWNTOWN SUPPORT DISTRICT:**

- A. Purpose Statement: The purpose of the D-2 Downtown Support District is to provide an area that fosters the development of a sustainable urban neighborhood that accommodates commercial, office, residential and other uses that relate to and support the Central Business District. Development within the D-2 Downtown Support District is intended to be less intensive than that of the Central Business District, with high lot coverage and buildings placed close to the sidewalk. This district is appropriate in areas where supported by applicable master plans. Design standards are intended to promote pedestrian oriented development with a strong emphasis on a safe and attractive streetscape.
- B. Uses: Uses in the D-2 Downtown Support District, as specified in Section 21A.33.050, "Table of Permitted and Conditional Uses for Downtown Districts", of this title, are permitted subject to the general provisions set forth in Section 21A.30.010 of this chapter and this section.
- C. Lot Size Requirements: No minimum lot area or lot width shall be required.
- D. Maximum Building Height: The maximum permitted building height shall not exceed 120' subject to the following review process: Buildings over 65' in height are subject to design review according to the requirements of Chapter 21A.59 of this title.
- E. Yard Requirements:
- 1. Front and Corner Side Yard: There is no minimum setback. The maximum setback is 10 feet. Buildings that contain ground floor residential uses shall have a front yard setback of a minimum of 8' and a maximum setback no greater than 16'. A provided yard for any use shall be considered a landscaped yard and subject to the provisions of Chapter 21A.48 for required landscaped yards.
    - a. If provided, the yard must include one of the following elements:

- i. Seating at a ratio of at least one bench for every 500 square feet of yard space; or
    - ii. Landscaping that includes an increase of at least 25% in the total number of trees required to be planted on the site; or
    - iii. Awning or a similar form of weather protection that covers at least 5' in width and length from all street-facing building entrances.
  - b. Exceptions to this requirement may be authorized through the design review process, subject to the requirements of Chapter 21A.59 of this title.
  - c. The planning director, in consultation with the transportation director, may modify this requirement to accommodate a wider sidewalk if the adjacent public sidewalk is less than 15' wide and the resulting modification to the setback results in a more efficient public sidewalk. The planning director may waive this requirement for any addition, expansions, or intensification, which increases the floor area or parking requirement by less than 50% if the planning director finds the following:
    - i. The architecture of the addition is compatible with the architecture of the original structure or the surrounding architecture, or
    - ii. The addition reduces the extent of the noncompliance of the existing building.
  - d. Regardless of the setback provided, doors shall be setback a minimum distance to allow the door to operate without swinging into a right of way or midblock walkway.
2. Interior Side Yards: No Minimum side yard is required except a minimum of 10' is required when the side yard is adjacent to a zoning district with a maximum permitted height of 35' or less.
  3. Rear Yard: No minimum rear yard is required except a minimum of 10' is required when the rear yard is adjacent to a zoning district with a maximum permitted height of 35' or less.
  4. Buffer Yards: Any lot abutting a lot in a residential district shall conform to the buffer yard requirements of Chapter 21A.48 of this title or the above standards, whichever is greater.

F. Existing Vehicle Sales or Lease Lots:

1. Vehicle Display Area: The parking provided in the vehicle display area will not be counted as off street parking when computing maximum parking requirements and is not considered to be a surface parking lot when determining required setbacks in this section.
2. Design Standards: Structures associated with accessory uses such as, but not limited to, repair shops or vehicle washing do not need to meet required design standards and

may exceed the maximum front and corner side yard setbacks. These structures are required to have one of the following elements listed below:

- a. Durable materials, as defined in Subsection 21A.37.050.B; or
- b. Landscaping.

Primary structures that contain sales floors and auto display areas must meet all design standards and setbacks.

3. Landscaping: A landscaped yard of at least 10' in depth is required along any portion of the street frontage of the property that is not occupied by a permanent structure. All other landscaping requirements in Chapter 21A.48 remain applicable.
4. Multiple Buildings: Vehicle sales or lease lots may have multiple buildings on a parcel subject to all buildings being associated with the use of the lot as vehicles sales or lease.

#### **21A.30.040: D-3 DOWNTOWN WAREHOUSE/RESIDENTIAL DISTRICT:**

- A. Purpose Statement: The purpose of the D-3 Downtown Warehouse/Residential District is to provide for the reuse of existing warehouse buildings for multi-family and mixed use while also allowing for continued retail, office and warehouse uses within the district. The reuse of existing buildings and the construction of new buildings are to be done as multi-family residential or mixed use developments containing retail or office uses on the lower floors and residential on the upper floors. This district is appropriate in areas where supported by applicable master plans. The standards are intended to create a unique and sustainable downtown neighborhood with a strong emphasis on urban design, adaptive reuse of existing buildings, alternative forms of transportation and pedestrian orientation.
- B. Uses: Uses in the D-3 Downtown Warehouse/Residential District as specified in Section 21A.33.050, "Table of Permitted and Conditional Uses for Downtown Districts", of this title, are permitted subject to the provisions of this chapter and other applicable provisions of this title.
- C. Lot Size Requirements: No minimum lot area or lot width shall be required.
- D. Yard Requirements: There are no minimum setbacks, except for buildings that contain ground floor residential uses in which case the front yard setback shall be a minimum of 8' and no greater than 16'. A provided front yard for any use shall be considered a landscaped yard and subject to the provision of Chapter 21A.48 for required landscaped yards. The maximum front yard setback shall be eight feet for all other uses.

1. The yard must be designed with usability as a consideration. Development that implements the maximum yard is required to have at least one of the following elements:
    - a. Seating at a ratio of at least one bench for every 500 square feet of yard space; or
    - b. Landscaping that includes an increase of at least 25% in the total number of trees required to be planted on the site; or
    - c. Awning or a similar form of weather protection that covers at least 5' in width and length from all street-facing building entrances.
  2. Exceptions to this requirement may be authorized through the design review process, subject to the requirements of Chapter 21A.59 of this title.
  3. The planning director, in consultation with the transportation director, may modify this requirement to accommodate a wider sidewalk if the adjacent public sidewalk is less than 15' wide and the resulting modification to the setback results in a more efficient public sidewalk. The planning director may waive this requirement for any addition, expansions, or intensification, which increases the floor area or parking requirement by less than 50% if the planning director finds the following:
    - a. The architecture of the addition is compatible with the architecture of the original structure or the surrounding architecture, or
    - b. The addition reduces the extent of the noncompliance of the existing building.
  4. Regardless of the setback provided, doors shall be setback a minimum distance to allow the door to operate without swinging into a right of way or midblock walkway.
- E. Maximum Building Height: Buildings in the D3 zoning district shall comply with the following provisions:
1. The permitted building height shall not exceed 75'.
  2. Buildings taller than 75' but less than 180' may be allowed subject to the following provisions:
    - a. Approval is subject to Chapter 21A.59 Design Review:
      - (1) Provided the additional height is supported by the applicable master plan.
      - (2) The building includes at least one of the following five options:
        - (A) Midblock walkway is provided on the property and the midblock walkway connects to an existing or planned street, midblock walkway, or publicly accessible public space and exceeds all the required dimensions of Subsection 21A.30.010.G by at least five feet. This option allows for additional height in return for exceeding the midblock walkway requirements;

- (B) The building is utilizing affordable housing incentives identified in Chapter 21A.52 of this title;
- (C) The property where the building is located exceeds the minimum requirement for ground floor uses identified in Chapter 21A.37 (Design Standards) of this title, specifically:
  - (i) For Subsection 21A.37.050.A.1 (Design Standards Defined, Ground Floor Use Only), the requirement must be increased to 100%. This option requires that the entire ground floor use of a building consists of retail good establishments, retail service establishments or restaurants, public service portions of businesses, department stores, art galleries, motion picture theaters, performing art facilities or similar uses that encourages walk-in traffic through an active use. Vehicle entry and exit ways necessary for access to parking are exempt from this requirement; or
  - (ii) For Subsection 21A.37.050.A.2 (Design Standards Defined, Ground Floor Use and Visual Interest), the ground floor use requirement must be increased to 75% and the visual interest requirement must be increased to 25%. This option requires for an increased percentage of ground floor space to be used for an active use, and an increased percentage of the building to provide visual interest;
- (D) The applicant provides a restrictive covenant on a historic building, a building that is 50 years or older, or a building that is a nationally recognized property, located outside of the H Historic Preservation Overlay District for the purpose of preserving the structure for a minimum of 50 years; or
- (E) The proposal includes a privately owned, publicly accessible open space on the property or on another property within the geographic boundaries of the Downtown Plan. To qualify for this provision, a restrictive covenant in the favor of the city shall be recorded against the open space portion of the property. The space shall be a minimum of 500 square feet and include enough trees to provide a shade canopy that covers at least 60% of the open space area. This option allows for additional height in return for the designation of open public open space.

**21A.30.045: D-4 DOWNTOWN SECONDARY CENTRAL BUSINESS DISTRICT:**

- A. Purpose Statement: The purpose of the D-4 Secondary Central Business District is to foster an environment consistent with the area’s function as a housing, entertainment, cultural, convention, business, and retail section of the city that supports the Central Business District. Development is intended to support the regional venues in the district,

such as the Salt Palace Convention Center, and to be less intense than in the Central Business District. This district is appropriate in areas where supported by applicable master plans. The standards are intended to achieve established objectives for urban and historic design, pedestrian amenities, and land use control, particularly in relation to retail commercial uses.

- B. Uses: Uses in the D-4 Secondary Central Business District as specified in Section 21A.33.050, “Table of Permitted and Conditional Uses for Downtown Districts”, of this title, are permitted subject to the general provisions set forth in Section 21A.30.010 of this chapter. In addition, all conditional uses in the D-4 District shall be subject to design evaluation and approval by the planning commission.
- C. Minimum Lot Size: No minimum lot area or lot width is required.
- D. Yard Requirements:
  - 1. Front and Corner Side Yards: No minimum yards are required, however, a maximum front yard setback of eight feet is allowed.
    - a. The yard must be designed with the usability as a consideration. Development that implements the maximum yard is required to have at least one of the following elements:
      - i. Seating at a ratio of at least one bench for every 500 square feet of yard space;
      - ii. Landscaping that includes an increase of at least 25% in the total number of trees required to be planted on the site; or
      - iii. Awning or a similar form of weather protection that covers at least 5’ in width and length from all street-facing building entrances.
    - b. Exceptions to this requirement may be authorized through the design review process, subject to the requirements of Chapter 21A.59 of this title.
    - c. The planning director, in consultation with the transportation director, may modify this requirement to accommodate a wider sidewalk if the adjacent public sidewalk is less than 15’ wide and the resulting modification to the setback results in a more efficient public sidewalk. The planning director may waive this requirement for any addition, expansions, or intensification, which increases the floor area or parking requirement by less than 50% if the planning director finds the following:
      - i. The architecture of the addition is compatible with the architecture of the original structure or the surrounding architecture, or
      - ii. The addition reduces the extent of the noncompliance of the existing building.

- d. Regardless of the setback provided, doors shall be setback a minimum distance to allow the door to operate without swinging into a right of way or midblock walkway.
  2. Interior Side Yards: No minimum side yard is required except a minimum of 10' is required when the side yard is adjacent to a zoning district with a maximum permitted height of 35' or less.
  3. Rear Yard: No minimum rear yard is required except a minimum of 10' is required when the rear yard is adjacent to a zoning district with a maximum permitted height of 35' or less.
- E. Building Height: Buildings in the D-4 zoning district shall comply with the following provisions:
1. The permitted building height shall not exceed 75'.
  2. Buildings taller than 75' and up to 120' may be authorized through the design review process, subject to the requirements of Chapter 21A.59 of this title.
    - a. Additional Height: Additional height may be authorized up to 120' if the street facing facades contain ground floor commercial uses other than parking for at least 75% of the street facing facades according to Chapter 21A.37 and subject to approval through the design review process in Chapter 21A.59.
    - b. Additional Permitted Height Location: Additional height greater than 120' but not more than 375' in height is permitted in the area bounded by:
      - (1) The centerlines of South Temple, West Temple, 200 South, and 200 West Streets; and
      - (2) Beginning at the Southeast Corner of Block 67, Plat 'A', Salt Lake City Survey, and running thence along the south line of said Block 67, N89°54'02"W 283.86 feet; thence N00°04'50"E 38.59 feet; thence N10°46'51"W 238.70 feet; thence N24°45'15"W 62.98 feet; thence S89°54'02"E 355.45 feet to the east line of said Block 67; thence along said east line S00°06'35"W 330.14 feet to the point of beginning. Contains 102,339 square feet, or 2.349 acres, more or less.



3. Buildings in excess of 120' up to 375' may be authorized subject to the following provisions:
  - a. Approval is subject to Chapter 21A.59 Design Review;
  - b. Shall include a minimum stepback of five feet or other architectural feature that can deflect snow and ice from falling directly onto a sidewalk, midblock walkway, or other public space. The stepback may be located above the height of the first floor and below 120' in height above the sidewalk or public space. Buildings that are clad in glass that totals less than 50% of the total wall surface area are exempt from this requirement;
  - c. The additional height is supported by the applicable master plan; and
  - d. The building includes at least one of the following five options:
    1. Midblock walkway is provided on the property and the midblock walkway connects to an existing or planned street, midblock walkway, or publicly accessible public space and exceeds all the required dimensions of Section 21A.30.010.G by at least five feet. This option allows for additional height in return for exceeding the midblock walkway requirements;
    2. The building is utilizing affordable housing incentives identified in chapter 21A.52 of this title;
    3. The property where the building is located exceeds the minimum requirement for ground floor uses identified in Chapter 21A.37 (Design Standards) of this title, specifically:
      - (1) For Subsection 21A.37.050.A.1 (Design Standards Defined, Ground Floor Use Only), the requirement must be increased to 100%. This option



requires that the entire ground floor use of a building consists of retail good establishments, retail service establishments or restaurants, public service portions of businesses, department stores, art galleries, motion picture theaters, performing art facilities or similar uses that encourages walk-in traffic through an active use. Vehicle entry and exit ways necessary for access to parking are exempt from this requirement.; or  
(2) For Subsection 21A.37.050.A.2 (Design Standards Defined, Ground Floor Use and Visual Interest), the ground floor use requirement must be increased to 75% and the visual interest requirement must be increased to 25%. This option requires for an increased percentage of ground floor space to be used for an active use, and an increased percentage of the building to provide visual interest;

(D) The applicant provides a restrictive covenant on a historic building, a building that is 50 years or older, or a building that is a nationally recognized property, located outside of the H Historic Preservation Overlay District for the purpose of preserving the structure for a minimum of 50 years.

(E) The proposal includes a privately owned, publicly accessible open space on the property or on another property within the geographic boundaries of the Downtown Plan. To qualify for this provision, a restrictive covenant in the favor of the city shall be recorded against the open space portion of the property. The space shall be a minimum of 500 square feet and include enough trees to provide a shade canopy that covers at least 60% of the open space area. This option allows for additional height in return for the designation of open public open space.

e. Exception: The first 50' of height shall not be set back from the street front more than five feet except that setbacks greater than five feet may be approved through the design review process or, has otherwise allowed by this code.

SECTION 6. Amending the Text of Chapter 21A.31. That Chapter 21A.30 of the *Salt Lake City Code* (Zoning: Gateway Districts), shall be and hereby is amended to read as follows:

**CHAPTER 21A.31  
GATEWAY DISTRICTS**

**SECTION:**

**21A.31.010: General Provisions**

**21A.31.020: G-MU Gateway-Mixed Use District**

## **21A.31.010: GENERAL PROVISIONS:**

- A. Statement of Intent: The G-MU Gateway-Mixed Use District is intended to provide an urban setting for residential and commercial, developments, and implement the objectives of the Downtown Plan through district regulations that reinforce the mixed use character of the area and encourage the development of urban neighborhoods containing supportive retail, service commercial, office, and high density residential.
- B. Uses: Uses in the G-MU Gateway-Mixed District as specified in Section 21A.33.060, “Table of Permitted and Conditional Uses in the Gateway District”, of this title, are permitted subject to the general provisions set forth in this section.
- C. Permitted Uses: The uses specified as permitted uses, in Section 21A.33.060, “Table of Permitted and Conditional Uses in the Gateway District”, of this title are permitted; provided, that they comply with all requirements of this chapter, the general standards set forth in Part IV of this title, and all other applicable requirements of this title.
- D. Conditional Uses: The uses specified as conditional uses in Section 21A.33.060, “Table of Permitted and Conditional Uses in the Gateway District”, of this title, shall be permitted in the G-MU Gateway-Mixed Use District provided they are approved pursuant to the standards and procedures for conditional uses set forth in Chapter 21A.54 of this title.
- E. Midblock Walkways: As part of the city’s plan for the downtown area, it is intended that midblock walkways be provided to increase pedestrian connectivity and overall livability downtown through the creation of an intricate pedestrian network. The city has adopted the Downtown Plan that includes a midblock walkway map and establishes a need for such walkways as the Downtown grows. Because the districts within the downtown area allow building heights that exceed those of other districts in the city, the requirement for a midblock walkway is considered to be necessary to alleviate pedestrian impacts on the public sidewalks by dispersing future use of the public sidewalks. This requirement implements the city’s Downtown Plan and provides visual relief from the additional height that is available in these zone districts when compared to the remainder of the city. All buildings constructed after the effective date hereof within the Downtown zoning districts shall conform to this officially adopted plan for midblock walkways, in addition to the following standards:
  - 1. Any new development shall provide a midblock walkway if a midblock walkway on the subject property has been identified in a master plan that has been adopted by the city.
  - 2. The following standards apply to the midblock walkway:
    - a. The midblock walkway must be a minimum of 15’ wide and include a minimum 6’ wide unobstructed path.

- b. The midblock walkway may be incorporated into the building provided it is open to the public. A sign shall be posted indicating that the public may use the walkway.
- c. Building encroachments into the midblock walkway are permitted if they include one or more of the following elements:
  - (1) Colonnades;
  - (2) Staircases;
  - (3) Balconies: All balconies must be located at the third story or above;
  - (4) Building overhangs and associated cantilever - These coverings may be between 9 and 14' above the level of the sidewalk. They shall provide a minimum depth of coverage of six feet and project no closer to the curb than three feet;
  - (5) Skybridge: A single skybridge is permitted. All skybridges must be located at the third, fourth, or fifth stories; and
  - (6) Other architectural element(s) not listed above that offers refuge from weather and/or provide publicly accessible usable space.

Illustration of Regulation 21A.31.010.E2 Midblock Walkways

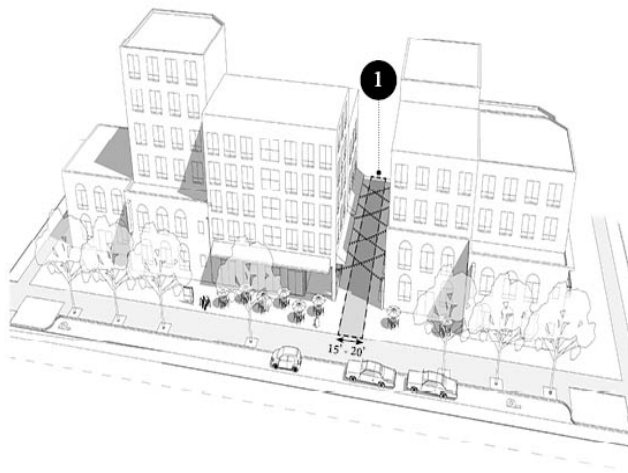

1	The midblock walkway must be a minimum of 15' wide and include a minimum 6' wide unobstructed path.
---	---

F. Modifications of Standards: A modification to the provisions of this chapter may be granted through the design review process, subject to conformance with the standards and procedures of Chapter 21A.59 of this title.

G. Midblock Street Development: Developments constructing midblock streets, either privately owned with a public easement or publicly dedicated, that are desired by an applicable master plan:

1. May transfer a portion or all of the above ground development square footage of the proposed new midblock street to other land within the proposed development.
2. May increase the height of the building on the remaining land within the development site to a height necessary to accommodate the development square footage of the proposed right of way that is being transferred.
3. Any proposal under this section shall be subject to conformance with the standards and procedures of Chapter 21A.59, “Design Review”, of this title.

H. Parking:

1. Belowground Parking Facilities: No special design and setback restrictions shall apply to belowground parking facilities.
2. Landscape Requirements: Surface parking lots shall have a landscaped setback of at least 20’ and meet interior landscaped requirements as outlined in Chapter 21A.48 of this title.
3. Design Review Approval: A modification to the restrictions on parking lots and structures provisions of this section may be granted through the design review process, subject to conformance with the standards and procedures of Chapter 21A.59 of this title. Such conditional uses shall also be subject to urban design evaluation.
4. Parking structures shall conform to the requirements set forth in Chapter 21A.37 of this title.

I. Outdoor Sales, Display and Storage: “Sales and display (outdoor)” and “storage and display (outdoor)”, is permitted for retail uses and the retail components of other permitted and conditional uses authorized in Section 21A.33.060 “Table of Permitted and Conditional Uses in the Gateway District. These uses shall conform to the following:

1. Outdoor sales and display and outdoor storage may also be permitted when part of an authorized temporary use as established in Chapter 21A.42 of this title;
2. The outdoor sales or display of merchandise shall not encroach into areas of required parking for longer than 30 days;
3. The outdoor permanent sales or display of merchandise shall not be located in any required yard area within the lot when the lot abuts a residential zoning district;
4. The outdoor sales or display of merchandise shall not include the use of banners, pennants or strings of pennants.

## **21A.31.020: G-MU GATEWAY-MIXED USE DISTRICT:**

- A. Purpose Statement: The G-MU Gateway-Mixed Use District is intended to implement the objectives of the adopted Downtown Plan and encourage the mixture of residential, commercial and assembly uses within an urban neighborhood atmosphere. The 200 South corridor is intended to encourage commercial development on an urban scale and the 500 West corridor is intended to be a primary residential corridor from North Temple to 400 South. Development in this district is intended to create an urban neighborhood that provides employment and economic development opportunities that are oriented toward the pedestrian with a strong emphasis on a safe and attractive streetscape. The standards are intended to achieve established objectives for urban and historic design, pedestrian amenities and land use regulation.
- B. Special Provisions:
1. Commercial Uses, 200 South: All buildings fronting 200 South shall have commercial uses that may include retail goods/service establishments, offices, restaurants, art galleries, motion picture theaters or performing arts facilities shall be provided on the first floor adjacent to the front or corner side lot line. The facades of such first floor shall be compatible and consistent with the associated retail or office portion of the building and other retail uses in the area.
  2. Residential Units, 500 West: Buildings fronting on 500 West shall be required to have residential units occupying a minimum of 50% of the structure's gross square footage.
- C. Building Height: The minimum building height shall be 75'. The maximum building height shall not exceed 180'.
1. Design Review: A modification to building height over ninety feet (90') in height shall only be allowed if approved through the design review process, subject to conformance with the standards and procedures of Chapter 21A.59 of this title, and subject to compliance to the applicable master plan.
- D. All buildings shall be designed with a base that is differentiated from the remainder of the building. The base shall be between one and three stories in height, be visible from pedestrian view, and appropriately scaled to the surrounding contiguous historic buildings. The base shall include fenestration that distinguishes the lower from upper floors. Insets and/or projections are encouraged. The ground floor of all new buildings shall have a minimum floor to ceiling height of 16'.
- E. Yard Requirements: No minimum setback requirements. A maximum setback of 10' is allowed for up to 30% of the building facade.

1. If provided, the yard must include one of the following elements:
  - a. Seating at a ratio of at least one bench for every 500 square feet of yard space; or
  - b. Landscaping that includes an increase of at least 25% in the total number of trees required to be planted on the site; or
  - c. Awning or a similar form of weather protection that covers at least 5' in width and length from all street-facing building entrances.
2. Regardless of the setback provided, doors shall be setback a minimum distance to allow the door to operate without swinging into a right of way or midblock walkway.
3. The planning director, in consultation with the transportation director, may modify this requirement to accommodate a wider sidewalk if the adjacent public sidewalk is less than 15' wide and the resulting modification to the setback results in a more efficient public sidewalk. The planning director may waive this requirement for any addition, expansion, or intensification, which increases the floor area or parking requirement by less than 50% if the planning director finds the following:
  - a. The architecture of the addition is compatible with the architecture of the original structure or the surrounding architecture, or
  - b. The addition reduces the extent of the noncompliance of the existing building.
4. Exceptions to this requirement may be authorized through the design review process, subject to the requirements of Chapter 21A.59 of this title.
5. Ground floor residential uses shall have a minimum setback of 10'. This setback shall be incorporated into a private yard for the ground floor units.

SECTION 7. Amending the Text of Section 21A.33.050. That Section 21A.33.050 of the *Salt Lake City Code* (Zoning: Land Use Tables: Table of Permitted and Conditional Uses for Downtown Districts), shall be and hereby is amended to read as follows:

**21A.33.050: TABLE OF PERMITTED AND CONDITIONAL USES FOR DOWNTOWN DISTRICTS:**

Legend:	C =	Conditional	P =	Permitted
---------	-----	-------------	-----	-----------

Use	Permitted And Conditional Uses By District			
	D-1	D-2	D-3	D-4

Accessory use, except those that are otherwise specifically regulated elsewhere in this title	P	P	P	P
Adaptive reuse of a landmark site	P	P	P	P <sup>4</sup>
Alcohol:				
Bar establishment (indoor)	P <sup>6</sup>	C <sup>6</sup>	C <sup>6</sup>	P <sup>6</sup>
Bar establishment (outdoor)	P <sup>6</sup>	C <sup>6</sup>	C <sup>6</sup>	P <sup>6</sup>
Brewpub (indoor)	P <sup>6</sup>	P <sup>6</sup>	P <sup>6</sup>	P <sup>6</sup>
Brewpub (outdoor)	P <sup>6</sup>	P <sup>6</sup>	P <sup>6</sup>	P <sup>6</sup>
Tavern (indoor)	P <sup>6</sup>	C <sup>6</sup>	C <sup>6</sup>	P <sup>6</sup>
Tavern (outdoor)	P <sup>6</sup>	C <sup>6</sup>	C <sup>6</sup>	P <sup>6</sup>
Animal, veterinary office		P	P	
Antenna, communication tower	P	P	P	P
Antenna, communication tower, exceeding the maximum building height	C	C	C	C
Art gallery	P	P	P	P
Artisan food production	P <sup>14,18</sup>	P <sup>18</sup>	P <sup>18</sup>	P <sup>18</sup>
Bed and breakfast	P	P	P	P
Bed and breakfast inn	P	P	P	P
Bed and breakfast manor	P	P	P	P
Bio-medical facility	P <sup>17,18</sup>	P <sup>17,18</sup>	P <sup>17,18</sup>	P <sup>17,18</sup>
Blood donation center		P		
Bus line station/terminal	P <sup>7</sup>	P <sup>7</sup>	P <sup>7</sup>	P <sup>7</sup>
Bus line yard and repair facility		P		
Car wash		P <sup>3</sup>		
Check cashing/payday loan business	P <sup>5</sup>			
Clinic (medical, dental)	P	P	P	P
Commercial food preparation	P <sup>18</sup>	P <sup>18</sup>	P <sup>18</sup>	P <sup>18</sup>
Community garden	P	P	P	P
Convention center				P
Crematorium	P	P	P	
Daycare center, adult	P	P	P	P
Daycare center, child	P	P	P	P
Daycare, nonregistered home daycare	P <sup>12</sup>	P <sup>12</sup>	P <sup>12</sup>	P <sup>12</sup>

Daycare, registered home daycare or preschool	P <sup>12</sup>	P <sup>12</sup>	P <sup>12</sup>	P <sup>12</sup>
Dwelling:				
Artists' loft/studio	P	P	P	P
Assisted living facility (large)	P	P	P	P
Assisted living facility (limited capacity)		P	P	P
Assisted living facility (small)	P	P	P	P
Congregate care facility (large)	C	C	C	C
Congregate care facility (small)	P	P	P	P
Group home (large)		C	C	
Group home (small)	P	P	P	P
Multi-family	P	P	P	P
Residential support (large)		C	C	
Residential support (small)		C	C	
Exhibition hall				P
Farmers' market			P	
Financial institution	P	P	P	P
Financial institution with drive-through facility		P <sup>8</sup>		P <sup>8</sup>
Funeral home	P	P	P	
Gas station		P	P <sup>7</sup>	P <sup>7</sup>
Government facility	C	C	C	C
Government facility requiring special design features for security purposes			P <sup>7</sup>	P <sup>7</sup>
Heliport, accessory	C	C		C
Home occupation	P <sup>13</sup>	P <sup>13</sup>	P <sup>13</sup>	P <sup>13</sup>
Homeless resource center		C <sup>15</sup>	C <sup>15</sup>	
Homeless shelter		C <sup>15</sup>	C <sup>15</sup>	
Hotel/motel	P	P	P	P
Industrial assembly		C <sup>18</sup>	C <sup>18</sup>	
Laboratory, medical related	P <sup>18</sup>	P <sup>18</sup>	P <sup>18</sup>	P <sup>18</sup>
Laundry, commercial		P <sup>18</sup>		
Library	P	P	P	P
Limousine service		P		
Mixed use development	P	P	P	P



Mobile food business (operation in the public right of way)	P	P	P	P
Mobile food business (operation on private property)	P	P	P	P
Mobile food court	P	P	P	P
Municipal services uses including city utility uses and police and fire stations	P	P	P	P
Museum	P	P	P	P
Office	P	P	P	P
Office, publishing company	P	P	P	P
Open space on lots less than 4 acres in size	P <sup>7</sup>	P <sup>7</sup>	P <sup>7</sup>	P <sup>7</sup>
Park	P	P	P	P
Parking, commercial	C <sup>19</sup>	P <sup>19</sup>	C <sup>19</sup>	C <sup>19</sup>
Parking, off site	P <sup>19</sup>	P <sup>19</sup>	P <sup>19</sup>	P <sup>19</sup>
Performing arts production facility	P	P	P	P
Place of worship	P <sup>11</sup>	P <sup>11</sup>	P <sup>11</sup>	P <sup>11</sup>
Radio, television station	P	P		P
Railroad, passenger station	P	P	P	P
Reception center	P	P	P	P
Recreation (indoor)	P	P	P	P
Recreation (outdoor)		P		
Research and development facility	P <sup>18</sup>	P <sup>18</sup>	P <sup>18</sup>	P <sup>18</sup>
Restaurant	P	P	P	P
Restaurant with drive-through facility		P <sup>8</sup>		
Retail goods establishment	P	P	P	P
Retail service establishment	P	P	P	P
Retail service establishment, upholstery shop		P	P	
Sales and display (outdoor)	P	P	P	P
School:				
College or university	P	P	P	P
K - 12 private			P	P
K - 12 public			P	P
Music conservatory	P	P	P	P
Professional and vocational	P	P	P	P
Seminary and religious institute	P	P	P	P

Small brewery		C <sup>18</sup>		
Social service mission and charity dining hall		C	C	
Stadium	C	C		C
Storage, self	P <sup>16</sup>	P	P	
Store:				
Department	P	P		P
Fashion oriented department	P <sup>2</sup>			
Mass merchandising	P	P		P
Pawnshop		P		
Specialty	P	P		P
Superstore and hypermarket		P		
Studio, art	P	P	P	P
Technology facility	P <sup>18</sup>	P <sup>18</sup>	P <sup>18</sup>	P <sup>18</sup>
Theater, live performance	P <sup>9</sup>	P <sup>9</sup>	P <sup>9</sup>	P <sup>9</sup>
Theater, movie	P	P	P	P
Utility, buildings or structure	P <sup>1</sup>	P <sup>1</sup>	P <sup>1</sup>	P <sup>1</sup>
Utility, transmission wire, line, pipe or pole	P <sup>1</sup>	P <sup>1</sup>	P <sup>1</sup>	P <sup>1</sup>
Vehicle:				
Automobile repair (major)		P	P <sup>7</sup>	P <sup>7</sup>
Automobile repair (minor)		P	P <sup>7</sup>	P <sup>7</sup>
Automobile sales/rental and service	P <sup>10</sup>	P	P <sup>10</sup>	
Vending cart, private property	P	P	P	P
Vending cart, public property				
Warehouse		P <sup>18</sup>		
Warehouse, accessory		P	P	
Wholesale distribution		P <sup>18</sup>		
Wireless telecommunications facility (see Section 21A.40.090, Table 21A.40.090.E of this title)				

Qualifying provisions:

1. Subject to conformance to the provisions in Subsection 21A.02.050.B of this title.
2. Uses allowed only within the boundaries and subject to the provisions of the Downtown Main Street Core Overlay District (Section 21A.34.110 of this title).

3. A car wash located within 165 feet (including streets) of a residential use shall not be allowed.
4. Building additions on lots less than 20,000 square feet for office uses may not exceed 50 percent of the building's footprint. Building additions greater than 50 percent of the building's footprint or new office building construction are subject to a design review (Chapter 21A.59 of this title).
5. No check cashing/payday loan business shall be located closer than 1/2 mile of other check cashing/payday loan businesses.
6. Subject to conformance with the provisions in Section 21A.36.300, "Alcohol Related Establishments", of this title.
7. Subject to conformance with the provisions of Chapter 21A.59, "Design Review", of this title.
8. Subject to conformance to the provisions in Section 21A.40.060 of this title for drive-through use regulations.
9. Prohibited within 1,000 feet of a single- or two-family zoning district.
10. Must be located in a fully enclosed building and entirely indoors.
11. If a place of worship is proposed to be located within 600 feet of a tavern, bar establishment, or brewpub, the place of worship must submit a written waiver of spacing requirement as a condition of approval.
12. Subject to Section 21A.36.130 of this title.
13. Allowed only within legal conforming single-family, duplex, and multi-family dwellings and subject to Section 21A.36.030 of this title.
14. Must contain retail component for on-site food sales.
15. Subject to conformance with the provisions of Section 21A.36.350 of this title.
16. Limited to basement/below ground levels only. Not allowed on the ground or upper levels of the building, with the exception of associated public leasing/office space.
17. Prohibited within 1/2 mile of a residential use if the facility produces hazardous or radioactive waste as defined by the Utah Department of Environmental Quality administrative rules.
18. Consult the water use and/or consumption limitations of Subsection 21A.33.010.D.1.
19. Parking lots, garages or parking structures, proposed as the only principal use on a property that has frontage on a public street that would result in a building demolition are prohibited subject to the provisions of Subsection 21A.30.010.F.3.

SECTION 8. Amending the Text of Section 21A.37.020. That Section 21A.37.020 of the *Salt Lake City Code* (Zoning: Design Standards: Applicability), shall be and hereby is amended to read as follows:

**21A.37.020: APPLICABILITY:**

The design standards identified in this chapter apply to all properties in the zoning districts listed in Section 21A.37.060 of this chapter pursuant to the following:

- A. Change in Use: A change in use shall be exempt from this chapter, provided that it does not result in alterations of existing design elements regulated by the standards of this chapter.
- B. Additions: When an addition to an existing structure is made, only the addition is subject to this chapter, provided that no existing design element regulated by these standards is altered in other portions of the existing structure.
- C. Repair, Maintenance or Alterations: Structures may be repaired, maintained or altered, except that no such work shall create a noncompliance or increase the degree of an existing noncompliance. If a design element of an existing structure complies with this chapter, the design element shall not be altered such that the structure becomes noncompliant.
- D. Certificate of Appropriateness: All new construction, additions, exterior building work, structure work, and site work on property in an H Historic Preservation Overlay District or a landmark site remains subject to a certificate of appropriateness as required in Subsection 21A.34.020.E of this title.

SECTION 9. Amending the Text of Section 21A.37.040. That Section 21A.37.040 of the *Salt Lake City Code* (Zoning: Design Standards: Modifications of Design Standards), shall be and hereby is amended to read as follows:

**21A.37.040: MODIFICATIONS OF DESIGN STANDARDS:**

The planning director and/or planning commission may modify any of the design standards identified in this chapter subject to the requirements of Chapter 21A.59, “Design Review”, of this title. The applicant must demonstrate that the modification meets the intent for the specific design standards requested to be modified, the standards for design review and any adopted design guidelines that may apply.

- A. The planning director may approve, approve with modifications, deny or refer to the planning commission modifications to specific design standards when proposed as new construction, an addition or modification to the exterior of an existing structure, or a modification to an existing structure as authorized in Section 21A.59.040, Table 21A.59.040 or when authorized in the specific zoning district.

1. The director shall approve a request to modify a design standard if the director finds that the proposal complies with the purpose of the individual zoning district, the purpose of the individual design standards that are applicable to the project, the proposed modification is compatible with the development pattern of other buildings on the block face or on the block face on the opposite side of the street, and the project is compliant with the applicable design standards (Sections 21A.37.050 and 21A.37.060).
  2. The director may approve a request to modify a design standard with conditions or modifications to the design if the director determines a modification is necessary to:
    - a. Comply with the purpose of the base zoning district;
    - b. Comply with the purpose of the applicable design standards of the base zoning;
    - c. Achieve compatibility with the development pattern of other buildings on the block face or on the block face on the opposite side of the street;
    - d. Achieve the applicable design review objectives; or
    - e. Encourage the reuse of existing buildings when a modification to a noncomplying building results in the building becoming closer to complying with a specific design standard.
  3. The director shall deny a request to modify a design standard if the design does not comply with the purpose of the base zoning district, the purpose of the applicable design standards or the applicable design review objectives and no modifications or conditions of approval can be applied that would make the design comply.
  4. The director may forward a request to modify a design standard to the planning commission if the director finds that the request for modification is greater than allowed by this chapter, a person receiving notice of the proposed modification can demonstrate that the request will negatively impact their property, or at the request of the applicant if the director is required to deny the request as provided in this section.
- B. For properties subject to the H Historic Preservation Overlay District, the historic landmark commission may modify any of the design standards in this chapter as part of the review of the standards in Section 21A.34.020 of this title.

SECTION 10. Amending the Text of Section 21A.37.050. That Section 21A.37.050 of the *Salt Lake City Code* (Zoning: Design Standards: Design Standards Defined), shall be and hereby is amended to read as follows:

**21A.37.050: DESIGN STANDARDS DEFINED:**

The design standards in this chapter are defined as follows. Each design standard includes a specific definition of the standard and may include a graphic that is intended to help further explain the standard; however, in cases where a conflict exists between the definition and the graphic, the definition shall take precedence. The table that follows (Section 21A.37.060) highlights the connection between each design standard and the zoning districts. It identifies whether a standard is required or not. Standards that are required are identified by an X or a number referencing the applicable standard. If there is a specific detail for the standard, it will also be identified in the table.

A. Ground Floor Use and Visual Interest: This standard's purpose is to increase the amount of active uses and/or visual interest on the ground floor of a building. Active uses are those that support the vibrancy and usability of the public realm adjacent to a building, and encourage walk-in traffic. There are two options for achieving this, one dealing solely with the amount of ground floor use, and the other combining a lesser amount of ground floor use with increased visual interest in the building facade's design. The majority of the ground level facade of a building shall be placed parallel, and not at an angle, to the street.

1. Ground Floor Use Only: This option requires that a portion of the length of any street-facing building facade on the ground floor of a new principal building include active uses allowed in the zoning district other than parking. Active uses include retail establishments, retail services, civic spaces (theaters, museums, etc), restaurants, bars, art and craft studios, and other uses determined to be substantially similar by the planning director and/or planning commission. Unless other uses are specifically required by this title, residential uses may count towards the ground floor use requirement. The ground floor of all new buildings shall have a minimum floor to ceiling height of 16'. The ground floor use shall not consist of spaces that discourage walk-in traffic, such as a residential mailroom, common room, back of house functions, or private business offices associated with an active use. Allowed uses shall occupy a minimum percentage of the length of the street facing facade according to Table 21A.37.060 of this chapter. All portions of such ground floor spaces shall extend a minimum of 25' into the building. Parking may be located behind these spaces.
  - a. For single-family attached uses, the required use depth may be reduced to ten feet (10').
  - b. The TSA (Transit Station Area), R-MU-35 (Residential Mixed-Use), R-MU-45 (Residential Mixed-Use), FB-UN2 (Form Based Urban Neighborhood), FB-UN3 (Form Based Urban Neighborhood), FBUN-SC (Form Based Urban Neighborhood Special Corridor Core), FBUN-SE (Form Based Urban Neighborhood Special Corridor Edge), CSHBD (Sugar House Business District)

are not subject to the 16' minimum floor to ceiling height required by this section. A zoning district that has a similar requirement, that requirement shall apply.

- c. For single-family or two-family uses, garages occupying up to 50% of the length of the ground floor building facade are exempt from this requirement.
  - d. For all other uses, vehicle entry and exit ways necessary for access to parking are exempt from this requirement. Such accessways shall not exceed 30' in width. Individual dwelling unit garages do not qualify for this exemption.
  - e. Outdoor space may count for up to 25% of the required ground floor use requirement when the outdoor space is within a required or provided front or corner side yard setback if the outdoor space includes outdoor dining space, an outdoor recreation use, fenced off areas for pets, patio space with seating, or other similar use. The amount of outdoor space shall be calculated on a linear foot for linear foot basis.
  - f. Areas such as kitchens, storage, bicycle parking, and other areas that are not accessible to customers shall not be counted towards the requirement for ground floor use and visual interest.
2. **Ground Floor Use and Visual Interest:** This option allows for some flexibility in the amount of required ground floor use, but in return requires additional design requirements for the purpose of creating increased visual interest and pedestrian activity where the lower levels of buildings face streets or sidewalks. This option identifies a required percentage of ground floor space that must be an active use, and the percentage of the building which must provide visual interest. An applicant utilizing this option must proceed through the design review process, Chapter 21A.59), for review of the project for determination of the project's compliance with those standards, and in addition, whether the design contributes to increased visual interest through a combination of increased building material variety, architectural features, facade changes, art, and colors; and, increased pedestrian activity through permeability between the building and the adjacent public realm using niches, bays, gateways, porches, colonnades, stairs or other similar features to facilitate pedestrian interaction with the building.

Illustration of Regulation 21A.37.050.A.2 Ground Floor Use and Visual Interest

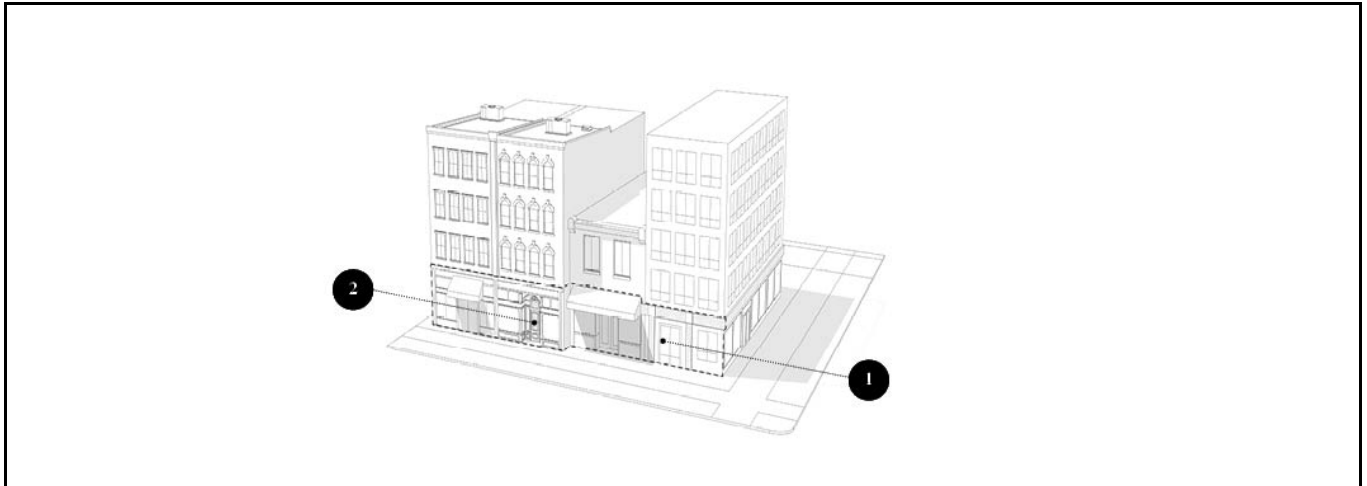

1	Contribute to increased visual interest through a combination of increased building material variety, architectural features, facade changes, art, and colors.
2	Contribute to increased pedestrian activity through a clear visual relationship between the building and the adjacent public realm using niches, bays, gateways, porches, colonnades, stairs or other similar features.

**B. Building Materials:**

1. All buildings which have been altered over 75% on the exterior facade shall comply with the material requirements detailed below. Buildings older than 50 years are exempt from this requirement if alterations are consistent with the existing architecture.
2. For the purpose of the requirements below, a durable material is defined as any material that has a manufacturer’s warranty of a minimum of 20 years or is a natural material such as stone or wood provided the wood is treated and maintained for exterior use.
3. Ground Floor Building Materials: Other than windows and doors, a minimum amount of the ground floor facade’s wall area of any street facing facade shall be clad in durable materials according to Section 21A.37.060, Table 21A.37.060 of this chapter. Durable materials include stone, brick, masonry, textured or patterned concrete, fiber cement board or other material that includes a minimum manufacturer warranty of 20 years from color fading, weather, and local climate induced degradation of the material. Other materials may be used for the remainder of the ground floor facade adjacent to a street. Other materials proposed to satisfy the durable requirement may be approved at the discretion of the planning director if it is found that the proposed material is durable and is appropriate for the ground floor of a structure.
4. Upper Floor Building Materials: Floors above the ground floor level shall include durable materials on a minimum amount of any street facing building facade of those



additional floors according to Section 21A.37.060, Table 21A.37.060 of this chapter. Windows and doors are not included in that minimum amount. Durable materials include stone, brick, masonry, textured or patterned concrete, and fiber cement board or other material that includes a minimum manufacturer warranty of 20 years from color fading, weather, and local climate induced degradation of the material.

C. Glass:

1. Ground Floor Glass: The ground floor building elevation of all new buildings facing a street, and all new ground floor additions facing a street, shall have a minimum percentage of glass, as calculated-between three feet and eight feet above grade according to Section 21A.37.060, Table 21A.37.060 of this chapter. All ground floor glass shall allow unhampered and unobstructed visibility into the building for a depth of at least five feet, excluding any glass etching and window signs when installed and permitted in accordance with Chapter 21A.46, "Signs", of this title. The planning director may approve a modification to ground floor glass requirements if the planning director finds:
  - a. The requirement would negatively affect the historic character of an existing building;
  - b. The requirement would negatively affect the structural stability of an existing building; or
  - c. The ground level of the building is occupied by residential uses that face the street, in which case the specified minimum glass requirement may be reduced by 15%.

Illustration of Regulation 21A.37.050.C.1 Ground Floor Glass (References the measurements in Table D, D-1)

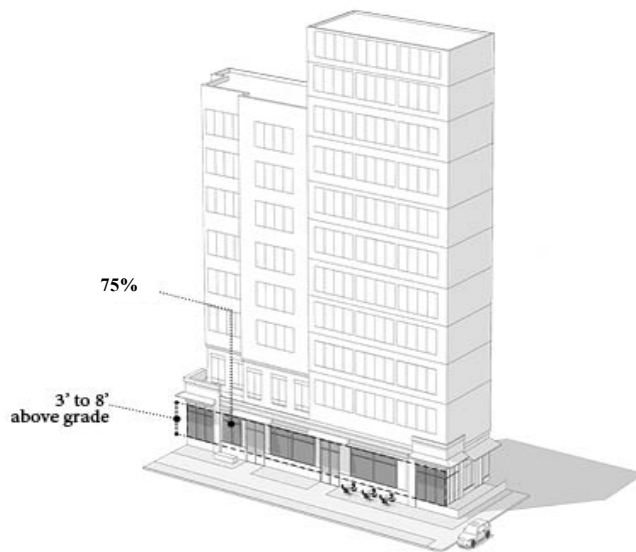

1 The ground floor building elevation of all new buildings facing a street, and all new ground floor additions facing a street, shall have a minimum percentage of glass as indicated in the associated tables in this chapter, between three feet and eight feet above grade.

2. Upper Floor Glass: Above the first floor of any multi-story building, the surface area of the facade of each floor facing a street must contain a minimum percentage of glass according to Section 21A.37.060, Table 21A.37.060 of this chapter.
  - a. Reflective Glass: The maximum percentage of reflective glass, defined as glass with a coating that creates a mirror-like appearance, is allowed according to Section 21A.37.060, Table 21A.37.060 of this chapter, on both the ground floor and upper floor of buildings.

D. Building Entrances: A building entrance is defined as an entrance to a building that includes a door and entry feature such as a recess or canopy that provides customers with direct access to the use. For the purpose of this provision, an operable building entrance shall be open and accessible during the hours that the business is open and comply with applicable ADA standards. At least one operable building entrance on the ground floor is required for every street facing facade. Additional operable building entrances shall be required, at a minimum, at each specified length of street facing building facade according to Section 21A.37.060, Table 21A.37.060 of this chapter. The center of each additional entrance shall be located within six feet either direction of the specified location. Each ground floor nonresidential leasable space facing a street shall have an

operable entrance facing that street and a walkway to the nearest sidewalk. Corner entrances, when facing a street and located at approximately a 45° angle to the two adjacent building facades (chamfered corner), may count as an entrance for both of the adjacent facades.

Illustration of Regulation 21A.37.050.D Building Entrances (References the measurements in Table D, D-1)

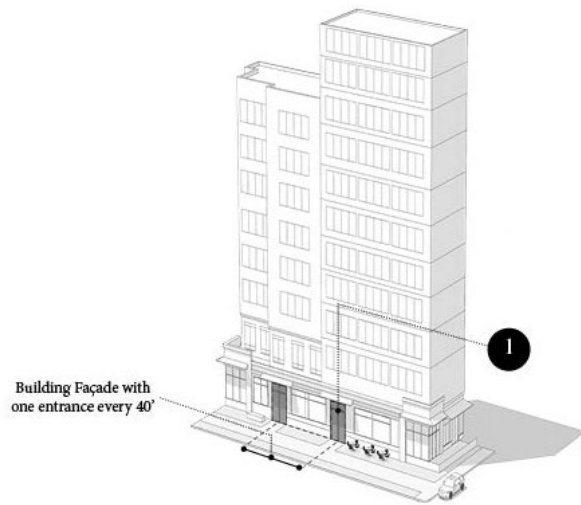

1	At least one operable building entrance on the ground floor is required for every street facing facade. Additional operable building entrances shall be required, at a minimum distance as indicated in the associated tables in this chapter.
---	--

E. Maximum Length of Blank Wall: The maximum length of any blank wall uninterrupted by windows, doors, art or architectural detailing at the ground floor level along any street facing facade shall be as specified according to Section 21A.37.060, Table 21A.37.060 of this chapter. Changes in plane, texture, materials, scale of materials, patterns, art, or other architectural detailing are acceptable methods to create variety and scale. This shall include architectural features such as bay windows, recessed or projected entrances, windows, balconies, cornices, columns, or other similar architectural features. The architectural feature shall be either recessed a minimum of 12” or projected a minimum of 12”.

Illustration of Regulation 21A.37.050.E Maximum Length of Blank Wall (References the measurements in Table D, Downtown Districts)

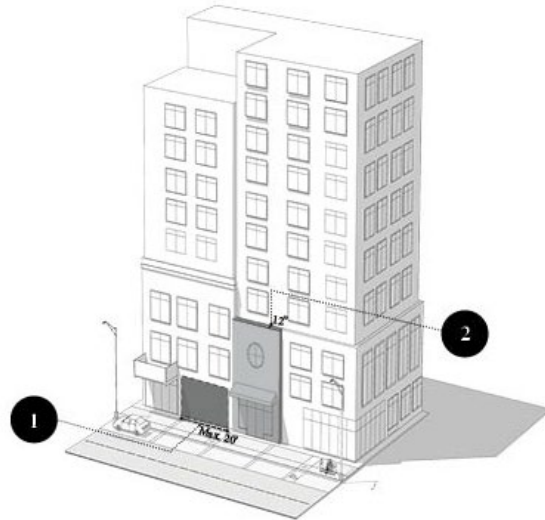

1	The maximum length of any blank wall uninterrupted by windows, doors, art or architectural detailing at the ground floor level along any street facing façade shall be limited to the specified measurement indicated in the associated table in this chapter.
2	The architectural feature shall be either recessed a minimum of 12” or projected a minimum of 12”.

F. Maximum Length of Street Facing Facades: This requirement sets the maximum length of a single street facing façade of a structure. The purpose of this is to have building massing that better responds to human scale to create a walkable pedestrian environment. No street facing building wall may be longer than specified along a street line according to Section 21A.37.060, Table 21A.37.060 of this chapter. A minimum of 20’ is required between separate buildings when multiple buildings are placed on a single parcel according to Subsection 21A.36.010.B, “One Principal Building Per Lot”, of this title. The space between buildings shall include a pedestrian walkway at least five feet wide.

G. Upper Floor Stepback:

1. The upper floor stepback for street facing facades is dependent on the height of the building according to Section 21A.37.060, Table 21A.37.060 of this chapter. For buildings that are between 78’ to 104’, or between 6 and 8 stories, a minimum stepback of 10’ is required at least 25’ above grade. For buildings above 105’, or 8 stories, the step back shall be a minimum of 15’ from the property line. The stepback

shall appear after the first two to five floors. In addition to these provisions, 20% of the entire building façade can meet the street at the lot line with no stepback. An alternative to this street facing facade stepback requirement may be utilized for buildings limited to 45’ or less in height by the zoning ordinance: those buildings may provide a 4’ minimum depth canopy, roof structure, or balcony that extends from the face of the building toward the street at a height of between 12’ and 15’ above the adjacent sidewalk. Such extension(s) shall extend horizontally parallel to the street for a minimum of 50% of the face of the building and may encroach into a setback as permitted per Section 21A.36.020, Table 21A.36.020.B, “Obstructions in Required Yards”, of this title.

Illustration of Regulation 21A.37.050.G1 Upper Floor Stepback

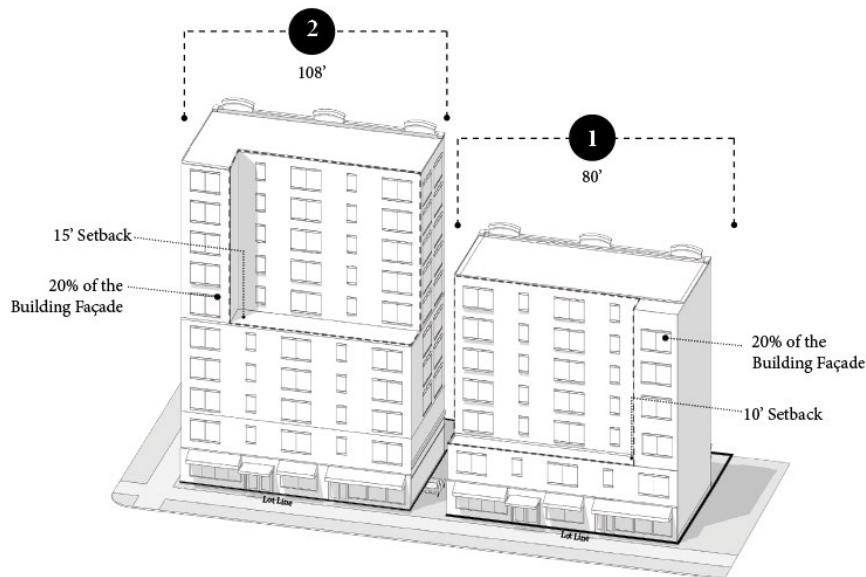

1	For buildings that are between 78’ to 104’, or between 6 and 8 stories, a minimum stepback of 10’ is required at least 25’ above grade. The stepback shall appear after the first 26’ to 65’, or 2 to 5 floors. In addition to these provisions, 20% of the entire building façade can meet the street at the lot line with no stepback.
2	For buildings above 104’, or 8 stories, the stepback shall be a minimum of 15’ from the property line. The stepback shall appear after the first 26’ to 65’, or 2 to 5 floors. In addition to these provisions, 20% of the entire building façade can meet the street at the lot line with no stepback.

- Stepbacks are required for full floors above the height, according to Section 21A.37.060, Table 21A.37.060 of this chapter, measured from average finished grade that have facades facing single- or two-family residential districts with a permitted height that is 35’ or less, a public trail or public open space. The purpose of this

- provision is to reduce the impact that buildings over a certain height have on abutting properties when the abutting properties have a permitted height that is 35' or less.
3. For street facing facades the first full floor, and all additional floors, above thirty feet (30') in height from average finished grade shall be stepped back a minimum horizontal distance from the front line of building, according to Section 21A.37.060, Table 21A.37.060 of this chapter. An alternative to this street facing facade step back requirement may be utilized for buildings limited to forty five feet (45') or less in height by the zoning ordinance: those buildings may provide a four foot (4') minimum depth canopy, roof structure, or balcony that extends from the face of the building toward the street at a height of between twelve feet (12') and fifteen feet (15') above the adjacent sidewalk. Such extension(s) shall extend horizontally parallel to the street for a minimum of fifty percent (50%) of the face of the building and may encroach into a setback as permitted per Section 21A.36.020, Table 21A.36.020.B, "Obstructions in Required Yards", of this title.
  4. Floors rising above thirty feet (30') in height shall be stepped back fifteen (15) horizontal feet from the building foundation at grade for building elevations that are adjacent to a public street, public trail, or public open space. This stepback does not apply to buildings that have balconies on floors rising above thirty feet (30') in height.
- H. Exterior Lighting: All exterior lighting shall be shielded and directed down to prevent light trespass onto adjacent properties. Exterior lighting shall not strobe, flash or flicker.
- I. Parking Lot Lighting: If a parking lot/structure is adjacent to a residential zoning district or land use, any poles for the parking lot/structure security lighting are limited to 16' in height and the globe must be shielded and the lighting directed down to minimize light encroachment onto adjacent residential properties or into upper level residential units in multi-story buildings. Lightproof fencing is required adjacent to residential properties.
- J. Screening of Mechanical Equipment: All mechanical equipment for a building shall be screened from public view and sited to minimize their visibility and impact. Examples of such impact-minimizing siting include on the roof, enclosed or otherwise integrated into the architectural design of the building, or in a rear or side yard area subject to yard location restrictions found in Section 21A.36.020, Table 21A.36.020.B, "Obstructions in Required Yards", of this title.
- K. Screening of Service Areas: Service areas, loading docks, refuse containers, utility meters, and similar areas shall be fully screened from public view. All screening enclosures viewable from the street shall be either incorporated into the building architecture or shall incorporate building materials and detailing compatible with the building being served. Waste and loading facilities are prohibited from being located on street-facing facades and shall be co-located and screened when possible. Exceptions to

this requirement may be approved by the planning director when the service provides power or some form of utilities in and around the surrounding area. Exemptions may also be approved through the site plan review process when a permit applicant demonstrates that it is not feasible to accommodate these activities on the block interior. If such activities are permitted adjacent to a public street, a visual screening design approved by the planning director shall be required.

All screening devices shall be a minimum of one foot higher than the object being screened, and in the case of fences and/or masonry walls the height shall not exceed eight feet. Dumpsters must be located a minimum of 25' from any building on an adjacent lot that contains a residential dwelling or be located inside of an enclosed building or structure.

- L. Ground Floor Residential Entrances for Dwellings with Individual Unit Entries: For the zoning districts listed in Section 21A.37.060, Table 21A.37.060 of this chapter, all attached dwellings including attached single-family dwellings, townhomes, row houses, multi-family developments with ground floor uses, and other similar housing types located on the ground floor shall have a primary entrance facing the street for each unit adjacent to a street. Units may have a primary entrance located on a courtyard, midblock walkway, or other similar area if the street facing facades also have a primary entrance.
- M. Parking Garages or Structures: The following standards shall apply to parking garages or structures whether stand alone or incorporated into a building:
  - 1. Parking structures shall have an external skin designed to improve visual character when adjacent to a public street or other public space. Examples include heavy gauge metal screen, precast concrete panels; live green or landscaped walls, laminated or safety glass, decorative photovoltaic panels or match the building materials and character of the principal use. The planning director may approve other decorative materials not listed if the materials are in keeping with the decorative nature of the parking structure.
  - 2. Facade elements shall align to parking levels and there shall be no sloped surfaces visible from a public street, public trail or public open space.
  - 3. Internal circulation must be designed such that parking surfaces are level (or without any slopes) along all primary facades. All ramping between levels need to be placed along the secondary facade or to the center of the structure. Parking structures shall be designed to conceal the view of all parked cars and drive ramps from public spaces.
  - 4. Elevator and stairs shall be highlighted architecturally so visitors can easily access these entry points both internally and externally.

5. Signage and wayfinding shall be integrated with the architecture of the parking structure and be architecturally compatible with the design. The entrances of public parking structures shall be clearly signed from public streets.
6. Interior garage lighting shall not produce glaring sources toward adjacent properties while providing safe and adequate lighting levels. The use of sensor dimmable LEDs and white stained ceilings are a good strategy to control light levels on site while improving energy efficiency.
7. Where a driveway crosses a public sidewalk, the driveway shall be a different color, texture, or paving material than the sidewalk to warn drivers of the possibility of pedestrians in the area.
8. The ground floor of all parking structures shall be wrapped along all street frontages with habitable space that is occupied by a use that is allowed in the zone as a permitted or conditional use.
9. Parking structures shall be designed to minimize vehicle noise and odors on the public realm. Venting and fan locations shall not be located next to public spaces and shall be located as far as possible from adjacent residential land uses.
10. If the parking structure is adjacent to a midblock walkway, pedestrian oriented elements shall be provided. These may include, but are not limited to seating and vegetation.

N. Residential Character in RB District:

1. All roofs shall be pitched and of a hip or gable design except additions or expansions to existing buildings may be of the same roof design as the original building;
2. The remodeling of residential buildings for retail or office use shall be allowed only if the residential character of the exterior is maintained;
3. The front building elevation shall contain not more than 50% glass;
4. Signs shall conform with special sign regulations of Chapter 21A.46, "Signs", of this title;
5. Building orientation shall be to the front or corner side yard; and
6. Building additions shall consist of materials, color and exterior building design consistent with the existing structure, unless the entire structure is resurfaced.

O. Primary Entrance Design in SNB District: Primary entrance design shall consist of at least two of the following design elements at the primary entrance, so that the primary entrance is architecturally prominent and clearly visible from the abutting street.

1. Architectural details such as arches, friezes, tile work, canopies, or awnings.
2. Integral planters or wing walls that incorporate landscape or seating.
3. Enhanced exterior light fixtures such as wall sconces, light coves with concealed light sources, or decorative pedestal lights.



4. A repeating pattern of pilasters projecting from the facade wall by a minimum of eight inches or architectural or decorative columns.
5. Recessed entrances that include a minimum stepback of two feet from the primary facade and that include glass on the sidewalls.

P. Streetscape Standards: These standards are required for landscaping that is within the public right of way. This is defined as the space between the private property line and the back of the curb.

1. Tree Canopy Coverage: No tree canopy shall cover less than the specified percentage according to Section 21A.37.060, Table 21A.37.060 of this chapter. The defined percentage represents the canopy coverage at maturity. At installation, a minimum of 20% of all trees shall have a minimum caliper of 3”.

Illustration of Regulation 21A.37.050.P.1 Tree Canopy Coverage

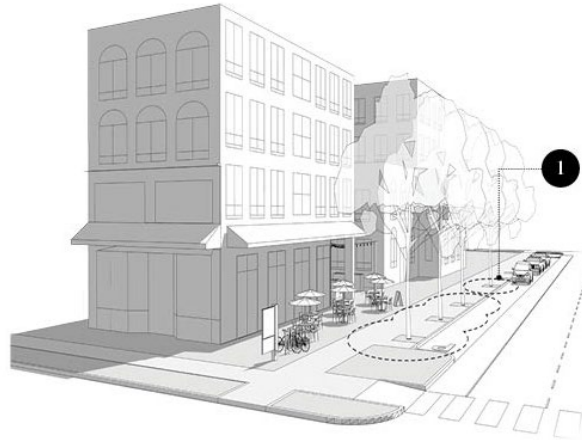

1	No tree canopy coverage shall cover less than the specified percentage according to Section 21A.37.060, Table 21A.37.060 of this chapter.
---	---

2. Minimum Vegetation Standards: The percentage of vegetation shall be no less than the specified amount according to Chapter 21A.48. The vegetation shall be planted in the public right of way.

Illustration of Regulation 21A.37.050.P.2 Minimum Vegetation Standards (References the measurements in Table D, Downtown Districts)

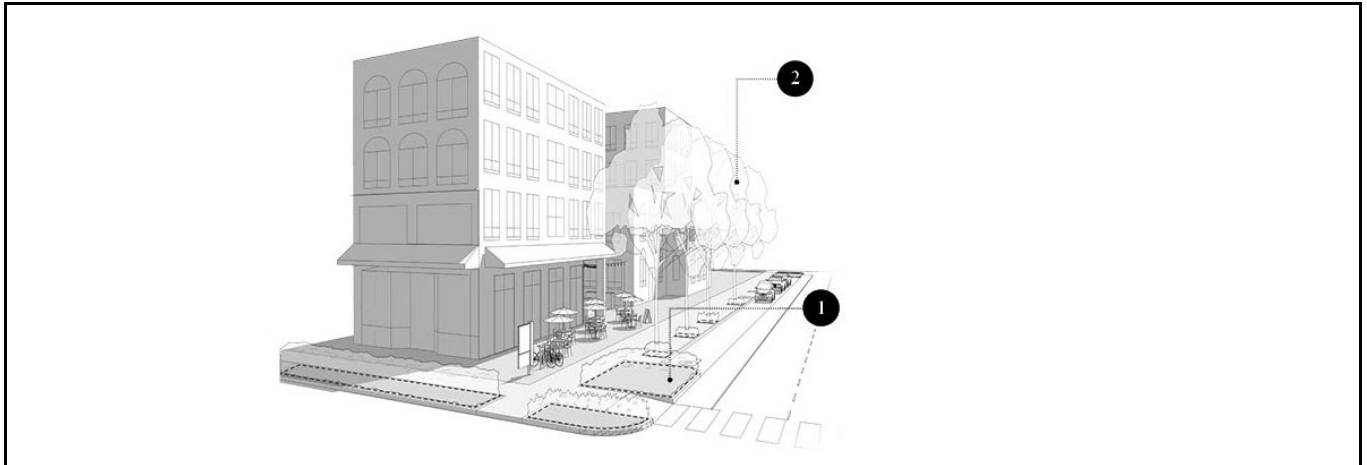

1	The percentage of vegetation shall be no less than the specified percentage according to Chapter 21A.48.
2	Vegetation shall be planted in the public right of way.

3. Street Trees: Street trees are required and subject to the regulations in Section 21A.48.080. In addition to those standards, for every new development, there shall be one street tree planted for every 30' of street frontage.
4. Soil Volume: In order to promote street tree health and longevity, each tree shall have an adequate volume of soil. The soil volume surrounding a tree shall be 750ft<sup>3</sup> to 1,000ft<sup>3</sup> per tree, provided that this area is exclusive of the soils volume calculation for adjacent trees. The soil volume may be reduced if under ground utilities are present within the soil volume and the soil volume cannot be extended horizontally due to other obstructions or barriers.

Illustration of Regulation 21A.37.050.P.4 Soil Volume

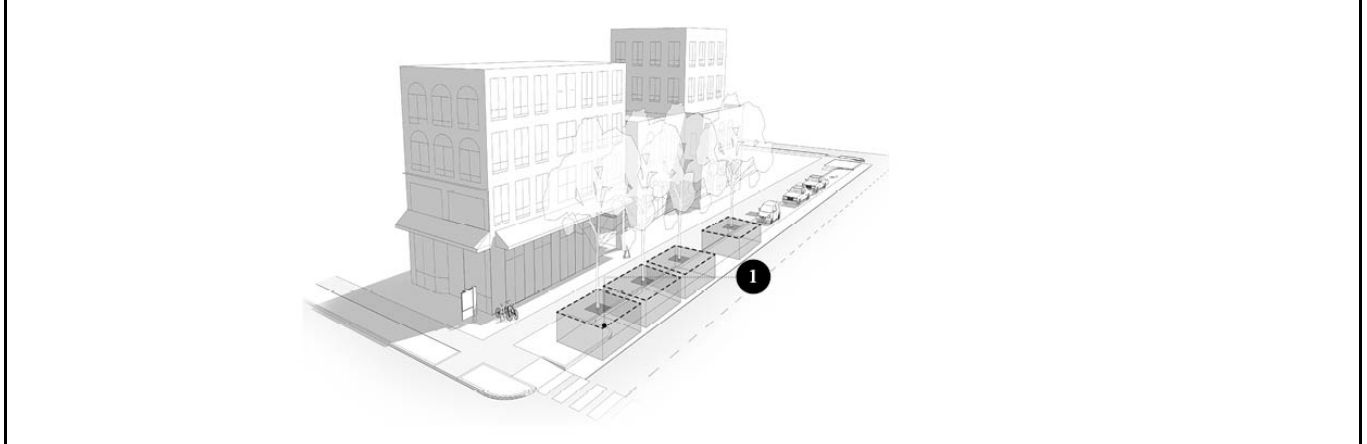

1	The soil volume surrounding a tree shall be 750ft <sup>3</sup> to 1,000ft <sup>3</sup> per tree, provided that this area is exclusive of the soils volume calculation for adjacent trees.
---	---

5. Minimize Curb Cuts: As an effort to emphasize the public realm and encourage the safety of pedestrians, places where cars intersect the street shall be minimized. More specifically, curb cuts are encouraged to be concentrated at midblock and alley locations. The sidewalk material shall continue at ground level of the curb cuts.

Illustration of Regulation 21A.37.050.P.5 Minimize Curb Cuts

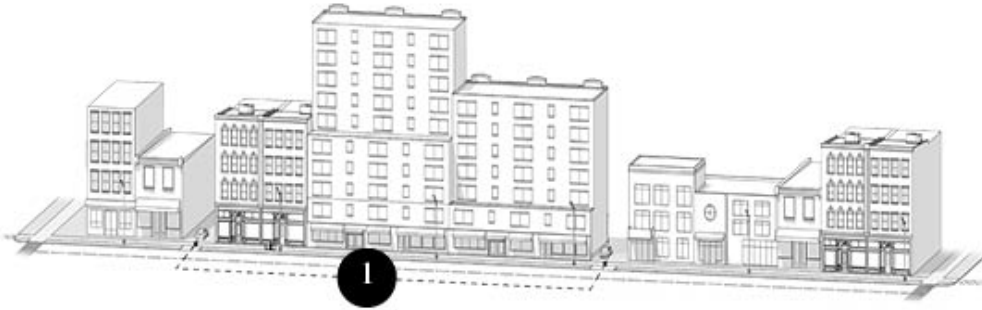

- |   |  |
|---|--|
| 1 | Curb cuts are encouraged to be concentrated at midblock and alley locations. |
|---|--|

6. Overhead Cover: Overhead covers are required at building entrances to provide weather protection to pedestrians and may encroach into a required yard as indicated in this section or into a public right of way with an approved encroachment agreement with the City. These coverings are required to be between 9 and 14' above the level of the sidewalk. They shall also provide coverage with a minimum depth of 6' and project no closer to the curb than 3'.

Illustration of Regulation 21A.37.050.P.6 Overhead Cover

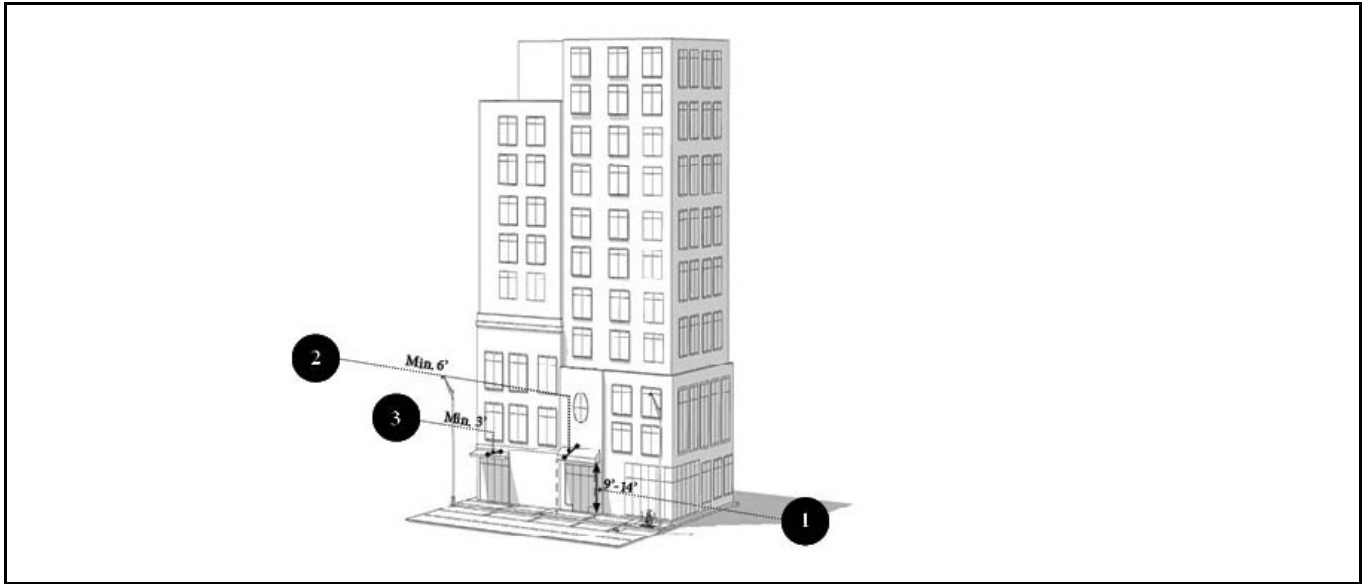

1	The shade structure shall occur between 9 and 14' above the level of the sidewalk.
	The shade shall provide a minimum coverage of 6' in width.
	The cover shall project no closer than 3' to the curb.

7. Streetscape Landscaping: All vegetation used along the streetscape must comply with the landscape requirements set forth in Chapter 21A.48.

Q. Height Transitions: This measurement is applied to control the size and shape of the building envelope or portion thereof for such purposes as promoting transition in scale between buildings of different height, protecting access to sunlight, and/or limiting shadow and overlook on neighboring properties. A transition may be achieved by relating a building's form to those that surround it through the following way. An angular plane of 45°, measured from the relevant property lines, should be used to provide a frame of reference for transition in scale from proposed high-rise buildings down to lower scale areas. The transition is required when development is directly adjacent to a zone with a height maximum of 35' or less or adjacent to a local historic landmark site. These standards do not apply when a right of way separates the buildings.

Illustration of Regulation 21A.37.050.Q Height Transitions

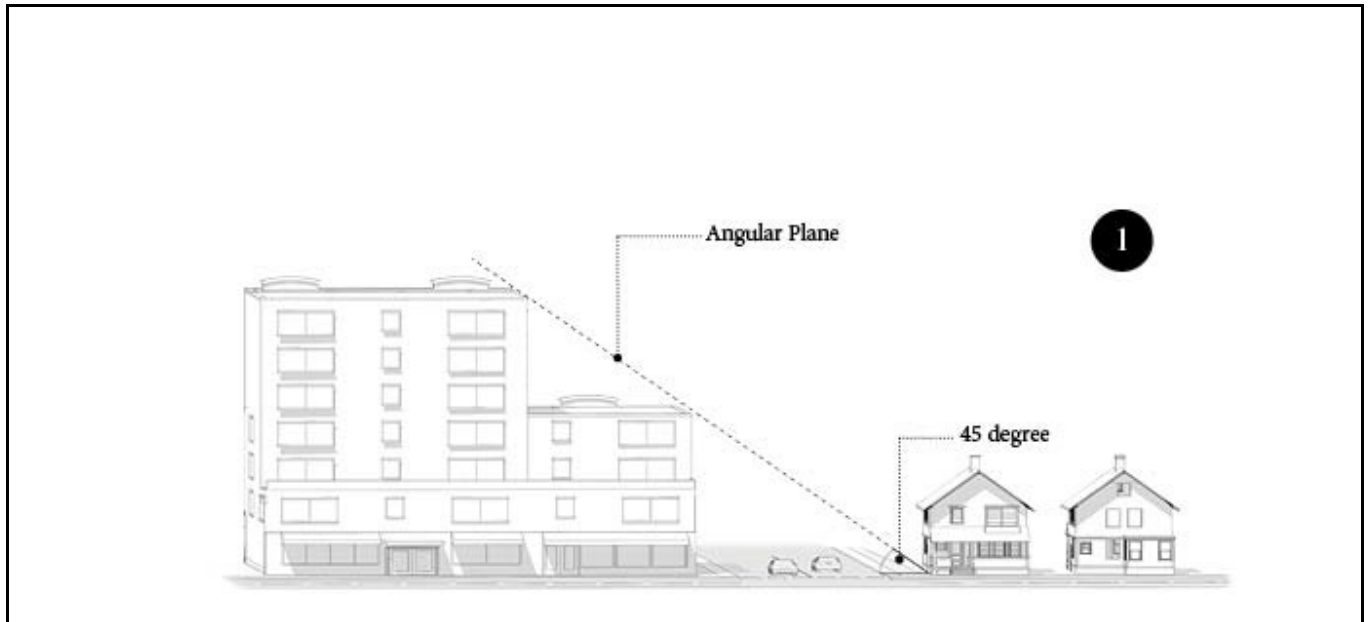

1 An angular plane of 45°, measured from the relevant property lines, should be used to provide a frame of reference for transition in scale from proposed high-rise buildings down to lower scale areas. The transition is required when development is adjacent to a zone with a height maximum of 35' or less or adjacent to a local historic landmark site.

- R. Horizontal articulation: Buildings shall be designed in such a way that they are appropriately scaled to the pedestrian at the street level. This scale is emphasized through authentic breaks in the façade. These breaks shall be articulated on the primary façade to the full height of the building to the cornice or to the full height of the building to the first horizontal setback. There may be a maximum spacing of 60' for horizontal articulation. Horizontal articulation shall be achieved through one of the following architectural features:
- a. Bay windows: Bay windows shall be a minimum of two feet in depth and four feet in width; or
  - b. Recessed entrances or windows: These shall be recessed a minimum of four feet in depth and six feet in width. Canopies or awnings are required at primary building entries; or
  - c. Niches: Niches shall be a minimum of two feet in depth and four feet in width; or
  - d. Openings for gates that are a minimum of four feet in width; or
  - e. Porches measuring at least 48 square feet; or
  - f. Colonnades that are a minimum of four feet in width.

SECTION 11. Amending the Text of Section 21A.37.060. That Section 21A.37.060 of the *Salt Lake City Code* (Zoning: Design Standards: Design Standards Required in Each Zoning District), shall be and hereby is amended to read as follows:

**21A.37.060: DESIGN STANDARDS REQUIRED IN EACH ZONING DISTRICT:**

This section identifies each design standard and to which zoning districts the standard applies. If a box is checked (X), that standard is required. If a box is blank, it is not required. If a specific dimension or detail of a design standard differs among zoning districts or differs from the definition, it will be indicated within the box. In cases where a dimension in this table conflicts with a dimension in the definition, the dimensions listed in the table shall take precedence.

TABLE 21A.37.060

A. Residential Districts:

Standard (Code Section)	District								
	RMF-30	RMF-35	RMF-45	RMF-75	RB	R-MU-35	R-MU-45	R-MU	RO
Ground floor use (%) (21A.37.050.A.1)						75	75		
Ground floor use + visual interest (%) (21A.37.050.A.2)									
Building materials: ground floor (%) (21A.37.050B.3)						80	80		
Building materials: upper floors (%) (21A.37.050.B.4)									
Glass: ground floor (%) (21A.37.050.C.1)						60	60	40	
Glass: upper floors (%) (21A.37.050.C.2)									
Building entrances (feet) (21A.37.050.D)						75	75	X	
Blank wall: maximum length (feet) (21A.37.050.E)						15	15	15	
Street facing facade: maximum length(feet) (21A.37.050.F)									
Upper floor stepback (feet) (21A.37.050.G.2 and 21A.37.050.G.3)							10		
Lighting: exterior (21A.37.050.H)									
Lighting: parking lot (21A.37.050.I)					X			X	
Screening of mechanical equipment(21A.37.050.J)						X	X	X	
Screening of service areas (21A.37.050.K.1)						X	X	X	
Ground floor residential entrances for dwellings with individual unit entries (21A.37.050.L)									

Parking garages or structures(21A.37.050.M)									
Residential character in RB District (21A.37.050.N)					X				

B. Commercial Districts:

Standard (Code Section)	District							
	SNB	CN	CB	CS	CC	CSHBD	CG <sup>1</sup>	TSA
Ground floor use (%) (21A.37.050.A.1)						80	80 <sup>2</sup>	80
Ground floor use + visual interest (%) (21A.37.050.A.2)						60/25	70/20	60/25
Building materials: ground floor (%) (21A.37.050.B.3)						80	70	90
Building materials: upper floors (%) (21A.37.050.B.4)						60		60
Glass: ground floor (%) (21A.37.050.C.1)	40	40	40			40	60	60
Glass: upper floors (%) (21A.37.050.C.2)							25	
Reflective Glass: ground floor (%) (21A.37.050.C.1)							0	
Reflective Glass: upper floors (%) (21A.37.050.C.2)							40	
Building entrances (feet) (21A.37.050.D)	X	X	X	X	X	40	40	40
Blank wall: maximum length (feet) (21A.37.050.E)	15	15	15			15	20	15
Street facing facade: maximum length (feet)(21A.37.050.F)						200	200	200
Upper floor setback (feet) (21A.37.050.G.2 and 21A.37.050.G.3)						15	X	
Facade height for required setback (21A.37.050.G.2)						30		
Lighting: exterior (21A.37.050.H)	X					X		X
Lighting: parking lot (21A.37.050.I)	X	X	X	X	X	X	X	X
Screening of mechanical equipment (21A.37.050.J)	X	X	X			X		X
Screening of service areas (21A.37.050.K)	X	X	X			X	X	X



Ground floor residential entrances for dwellings with individual unit entries (21A.37.050.L)								X
Parking garages or structures (21A.37.050.M)						X		
Primary entrance design SNB District (21A.37.050.O)	X							
Tree canopy coverage %(21A.37.050.P.1)							40	
Minimum vegetation standards (%) (21A.37.050.P.2)							X	
Street trees (21A.37.050.P.3)							X	
Soil volume (21A.37.050.P.4)							X	
Minimize curb cuts (21A.37.050.P.5)							X	
Overhead cover (21A.37.050.P.6)							X	
Streetscape landscaping (21A.37.050.P.7)							X	
Height transitions: angular plane for adjacent buildings (21A.37.050.Q)								
Horizontal articulation (21A.37.050.R)						X		

Notes:

1. These standards only apply to the portion of the CG district within the boundaries of north of 900 S, south of 200 S, west 300 W and east of I-15.
2. Maximum width of the entrance shall be 35' if the additional 20% is used for an entrance to a parking structure.

C. Manufacturing Districts:

Standard (Code Section)	District	
	M-1	M-2
Ground floor use (%) (21A.37.050.A.1)		
Ground floor use + visual interest (%) (21A.37.050.A.2)		
Building materials: ground floor (%) (21A.37.050.B.1)		
Building materials: upper floors (%) (21A.37.050.B.2)		
Glass: ground floor (%) (21A.37.050.C.1)		
Glass: upper floors (%) (21A.37.050.C.2)		
Building entrances (feet) (21A.37.050.D)		
Blank wall: maximum length (feet) (21A.37.050.E)		
Street facing facade: maximum length (feet) (21A.37.050.F)		
Upper floor stepback (feet) (21A.37.050.G)		
Lighting: exterior (21A.37.050.H)	X	X
Lighting: parking lot (21A.37.050.I)	X	X
Screening of mechanical equipment (21A.37.050.J)		

Screening of service areas (21A.37.050.K)		
Ground floor residential entrances (21A.37.050.L)		
Parking garages or structures (21A.37.050.M)		

D. Downtown Districts:

Standard (Code Section)	District			
	D-1	D-2	D-3	D-4
Ground floor use (%) (21A.37.050.A.1)	90	80	80	80
Ground floor use + visual interest (%) (21A.37.050.A.2)	80/10	70/20	70/20	70/20
Building materials: ground floor (%) (21A.37.050.B.1)	70	80	70 <sup>1</sup>	70
Building materials: upper floors (%) (21A.37.050.B.2)	50	50	70 <sup>1</sup>	50
Glass: ground floor (%) (21A.37.050.C.1)	60	60	60	60
Glass: upper floors (%) (21A.37.050.C.2)	50	50	50	50
Reflective Glass: ground floor (%) (21A.37.050.C.1)	0	0	0	0
Reflective Glass: upper floors (%) (21A.37.050.C.2)	50	50	50	50
Building entrances (feet) (21A.37.050.D)	40	40	60	60
Blank wall: maximum length (feet) (21A.37.050.E)	20	20	20	20
Street facing facade: maximum length (feet) (21A.37.050.F)	150	200	150	150
Upper floor stepback (feet) (21A.37.050.G.1)	X	X	X	X
Lighting: exterior (21A.37.050.H)		X		X

Lighting: parking lot (21A.37.050.I)		X		
Screening of mechanical equipment (21A.37.050.J)	X	X	X	X
Screening of service areas (21A.37.050.K)	X	X	X	X
Ground floor residential entrances for dwellings with individual unit entries (21A.37.050.L)				
Parking garages or structures (21A.37.050.M)	X <sup>2</sup>	X <sup>2</sup>		
Tree canopy coverage (%) (21A.37.050.P.1)	40	40	40	40
Minimum vegetation standards (21A.37.050.P.2)	X	X	X	X
Street trees (21A.37.050.P.3)	X	X	X	X
Soil volume (21A.37.050.P.4)	X	X	X	X
Minimize curb cuts (21A.37.050.P.5)	X	X	X	X
Overhead cover (21A.37.050.P.6)	X	X	X	X
Streetscape landscaping (21A.37.050.P.7)	X	X	X	X
Height transitions: angular plane for adjacent zone districts (21A.37.050.Q)		X	X	X
Horizontal articulation (21A.37.050.R)	X	X	X	X

Notes:

1. In the D-3 zoning district this percentage applies to all sides of the building, not just the front or street facing facade.
2. Parking structures shall be located behind principal buildings. This requirement may be modified so that structures may be located at least 15' from front and corner side lot lines if a minimum of seventy five percent (75%) of the ground floor adjacent to a sidewalk is used for retail goods/service establishments, office and/or restaurant space to encourage pedestrian activity. The facades of the ground floor shall be designed to be compatible and consistent with the associated retail or office portion of the building and other retail uses in the area.

E. Gateway Districts:

Standard (Code Section)	District
	G-MU
Ground floor use (%) (21A.37.050.A.1)	80
Ground floor use + visual interest (%) (21A.37.050.A.2)	70/20
Building materials: ground floor (%) (21A.37.050.B.1)	70
Building materials: upper floors (%) (21A.37.050.B.2)	50
Glass: ground floor (%) (21A.37.050.C.1)	60
Glass: upper floors (%) (21A.37.050.C.2)	50
Reflective Glass: ground floor (%) (21A.37.050.C.1)	0
Reflective Glass: upper floors (%) (21A.37.050.C.2)	50
Building entrances (feet) (21A.37.050.D)	40
Blank wall: maximum length (feet) (21A.37.050.E)	15
Street facing facade: maximum length (feet) (21A.37.050.F)	150
Upper floor stepback (feet) (21A.37.050.G.1)	X
Lighting: exterior (21A.37.050.H)	X <sup>1</sup>
Lighting: parking lot (21A.37.050.I)	X <sup>1</sup>
Screening of mechanical equipment (21A.37.050.J)	X
Screening of service areas (21A.37.050.K)	X
Ground floor residential entrances for dwellings with individual unit entries (21A.37.050.L)	

Parking garages or structures (21A.37.050.M)	X <sup>2</sup>
Tree canopy coverage (%) (21A.37.050.P.1)	40
Minimum vegetation standards (21A.37.050.P.2)	X
Street trees (21A.37.050.P.3)	X
Soil volume (21A.37.050.P.4)	X
Minimize curb cuts (21A.37.050.P.5)	X
Overhead cover (21A.37.050.P.6)	X
Streetscape landscaping (21A.37.050.P.7)	X
Height transitions: angular plane for adjacent zone districts (21A.37.050.Q)	X
Horizontal articulation (21A.37.050.R)	X

Notes:

1. Sidewalks and street lamps installed in the public right-of-way shall be of the type specified in the sidewalk/street lighting policy document adopted by the city.
2. Parking structures shall be located behind principal buildings. This requirement may be modified so that structures may be located at least 15' from front and corner side lot lines if a minimum of seventy five percent (75%) of the ground floor adjacent to a sidewalk is used for retail goods/service establishments, office and/or restaurant space to encourage pedestrian activity. The facades of the ground floor shall be designed to be compatible and consistent with the associated retail or office portion of the building and other retail uses in the area.

F. Special Purpose Districts:

Standard (Code Section)	District															
	RP	BP	FP	AG	AG-2	AG-5	AG-20	PL	PL-2	I	UI	OS	NOS	MH	EI	MU
Ground floor use (%) (21A.37.050.A.1)																
Ground floor use + visual interest (%) (21A.37.050.A.2)																
Building materials: ground floor (%) (21A.37.050.B.1)																
Building materials: upper floors (%) (21A.37.050.B.2)																
Glass: ground floor (%) (21A.37.050.C.1)																40-70
Glass: upper floors (%) (21A.37.050.C.2)																
Building entrances (feet) (21A.37.050.D)																X
Blank wall: maximum length (feet) (21A.37.050.E)																15
Street facing facade: maximum length (feet) (21A.37.050.F)																

Upper floor stepback (feet) (21A.37.050.G)																	
Lighting: exterior (21A.37.050.H)										X	X						X
Lighting: parking lot (21A.37.050.I)		X															X
Screening of mechanical equipment (21A.37.050.J)																	X
Screening of service areas (21A.37.050.K)																	X
Ground floor residential entrances (21A.37.050.L)																	
Parking garages or structures (21A.37.050.M)																	
Tree canopy coverage (%) (21A.37.050.P.1)																	
Minimum vegetation standards (21A.37.050.P.2)																	
Street trees (21A.37.050.P.3)																	
Soil Volume (21A.37.050.P.4)																	
Minimize curb cuts (21A.37.050.P.5)																	



Overhead cover (21A.37.050.P.6)																
Streetscape landscaping (21A.37.050.P.7)																
Height transitions: angular plane for adjacent zone districts (21A.37.050.Q)																
Horizontal articulation (21A.37.050.R)																

G. Form Based Districts:

Standard (Code Section)	District				
	FB-UN1	FB-UN2	FB-UN3	FB-SC	FB-SE
Ground floor use (%) (21A.37.050.A.1)		75	75 <sup>3</sup>	75	75
Ground floor use + visual interest (%) (21A.37.050.A.2)					
Building materials: ground floor (%) (21A.37.050.B.3)	70	70	70	70	70
Building materials: upper floors (%) (21A.37.050.B.4)	70	70	70	70	70
Glass: ground floor (%) (21A.37.050.C.1)	60 <sup>1</sup>	60 <sup>1</sup>	60 <sup>1</sup>	60 <sup>1</sup>	60 <sup>1</sup>
Glass: upper floors (%) (21A.37.050.C.2)	15	15	15	15	15
Reflective Glass: ground floor (%) (21A.37.050.C.1)					
Reflective Glass: upper floors (%) (21A.37.050.C.2)					
Building entrances (feet) (21A.37.050.D)	75	75	75	75	75
Blank wall: maximum length (feet) (21A.37.050.E)	15	15	30	30	30
Street facing facade: maximum length (feet) (21A.37.050.F)	200	200	200	200	200
Upper floor step back (feet) (21A.37.050.G.4)		X	X	X	X
Lighting: exterior (21A.37.050.H)	X	X	X	X	X
Lighting: parking lot (21A.37.050.I)	X	X	X		
Screening of mechanical equipment (21A.37.050.J)	X	X	X		

Screening of service areas (21A.37.050.K.1)	X	X	X <sup>2</sup>		
Ground floor residential entrances for dwellings with individual unit entries (21A.37.050.L)	X	X	X		
Parking garages or structures (21A.37.050.M)	X	X	X	X	X
Tree canopy coverage (%) (21A.37.050.P.1)	40	40	40		
Minimum vegetation standards (21A.37.050.P.2)	X	X	X		
Street trees (21A.37.050.P.3)	X	X	X	X	X
Soil volume (21A.37.050.P.4)	X	X	X		
Minimize curb cuts (21A.37.050.P.5)	X	X	X		
Overhead cover (21A.37.050.P.6)					
Streetscape landscaping (21A.37.050.P.7)	X	X	X		
Height transitions: angular plane for adjacent zone districts (21A.37.050.Q)	X	X	X		
Horizontal articulation (21A.37.050.R)	X	X	X		

Notes:

1. This may be reduced to twenty percent (20%) if the ground floor is within one of the following building types: urban house, two-family, cottage, and row house.
2. Except where specifically authorized by the zone.
3. For buildings with street facing facades over 100' in length, a minimum of 30% of the façade length shall be an “active use” as defined in Subsection 21A.37.050.A.1. Except for the rowhouse building form, residential units shall not count as an “active use” toward the 30% minimum.

SECTION 12. Amending the Text of Section 21A.44.060. That Section 21A.44.060 of the *Salt Lake City Code* (Zoning: Off Street Parking, Mobility and Loading), shall be and hereby is amended to read as follows:

**21A.44.060: PARKING LOCATION AND DESIGN:**

All required parking areas shall be located and designed in accordance with the standards in this Chapter 21A.44: *Off Street Parking, Mobility, and Loading* and the standards in the Off Street Parking Standards Manual. Modifications to the standards of this Section 21A.44.060 may be granted through the design review process, subject to conformance with the standards and procedures of Chapter 21A.59: Design Review.

A. Generally:

1. Parking Located on Same Lot as Use or Building Served: All parking spaces required to serve buildings or uses erected or established after the effective date of this ordinance shall be located on the same lot as the building or use served, unless otherwise allowed pursuant to Subsection 21A.44.060.A.4, “Off-Site Parking Permitted”.
2. Biodetention and Landscape Islands in General and Neighborhood Center Contexts: For parking lots with one hundred (100) or more parking spaces in the General Context and Neighborhood Center Context areas, parking lot islands or biodetention areas shall be provided on the interior of the parking lot to help direct traffic flow and to provide landscaped areas within such lots.
3. Parking Location and Setbacks: All parking shall comply with the parking restrictions within yards pursuant to Table 21A.44.060-A, “Parking Location and Setback Requirements”.

<b>TABLE 21A.44.060-A: PARKING LOCATION AND SETBACK REQUIREMENTS:</b>				
N = parking prohibited between lot line and front line of the principal building				
<b>Zoning District</b>	<b>Front Lot Line</b>	<b>Corner Side Lot Line</b>	<b>Interior Side Lot Line</b>	<b>Rear Lot Line</b>
<b>GENERAL CONTEXT</b>				
<b>Residential (FR Districts, RB, RMF, RO)</b>				
FR	N		6 ft.	
R-1, R-2, SR-1,	Parking in driveways that comply with all applicable city standards is exempt		0 ft.	

SR-2	from this restriction.			
RMF-30	N		0 ft.; or 10 ft. when abutting any 1-2 family residential district	0 ft.
RMF-35, RMF-45, RMF-75, RO			0 ft.; or 10 ft. when abutting any 1-2 family residential district. Limited to 1 side yard except for single-family attached lots.	
<b>Commercial and Manufacturing (CC, CS, CG, M-1, M-2, SNB)</b>				
CC	15 ft.		0 ft.; or 7 ft. when abutting any residential district	
CS			0 ft.; or 15 ft. when abutting any residential district	
CG	N. See also Subsection 21A.26.070.I			
M-1	15 ft.			
M-2			0 ft.; or 50 ft. when abutting any residential district	
<b>Special Purpose Districts</b>				
A	0 ft.		0 ft.	
AG, AG-2, AG-5, AG-20	N			
BP			8 ft.; or 30 ft. when abutting any residential district	
EI	10 ft.	30 ft.	30 ft.	20 ft.

FP		6 ft.	0 ft.
I	20 ft.	0 ft.; or 15 ft. when abutting any residential district	
MH		0 ft.	
OS	30 ft.	10 ft.	
PL		0 ft.; or 10 ft. when abutting any residential district	
PL-2	20 ft.		
RP	30 ft.	8 ft.; or 30 ft. when abutting any residential district	
<b>NEIGHBORHOOD CENTER CONTEXT</b>			
CB , CN, SNB	N	0 ft.; or 7 ft. when abutting any 1-2 family residential district	
R-MU-35, R-MU-45	Surface Parking: N Parking Structures: 45' or located behind principal building	Limited to 1 side yard, 0 ft.; or 10 ft. when abutting any 1-2 family residential district	0 ft.; or 10 ft. when abutting any 1-2 family residential district
RB, SR-3, FB-UN1, FB-SE	N	0 ft.	
<b>URBAN CENTER CONTEXT</b>			
CSHBD1	N	0 ft.; or 7 ft. when abutting any residential district	
CSHBD2		0 ft.; or 7 ft. when abutting any 1-2 family residential district	
D-2	Surface Parking: N Surface parking must be located behind the principal structure and comply with other requirements of Subsection	0 ft.	

	21A.30.010.F Parking Structures: N		
MU	Surface Parking: 25 ft. or located behind principal structure Parking Structures: 45 ft. or located behind principal structure	0 ft.; limited to 1 side yard	0 ft.
TSA-T	See Subsection 21A.44.060.B.2	0 ft.	
<b>TRANSIT CONTEXT</b>			
D-1	See Subsection 21A.44.060.B.1		
D-3			
D-4	See Subsections 21A.44.060.B.1, 21A.30.010.F and 21A.31.010.H	0 ft.	
G-MU			
FB-UN2, FB-UN3, FB-SC	N		
TSA-C	See Subsection 21A.44.060.B.2		
R-MU	Surface Parking: 30 ft. Parking Structures: 45 ft. or located behind principal structure	0 ft.; or 10 ft. when abutting any 1-2 family residential district  Surface parking at least 30 ft. from front lot line.	0 ft.; or 10 ft. when abutting any 1-2 family residential district
UI	0 ft; Hospitals: 30 ft.	0 ft.; or 15 ft. when abutting any 1-2 family residential district; Hospitals: 10 ft.	0 ft.; or 15 ft. when abutting any 1-2 family residential district; Hospitals: 10 ft.

4. Off-Site Parking Permitted: When allowed as either a permitted or conditional use per Chapter 21A.33, “Land Use Tables”, off-site parking facilities may be used to satisfy the requirements of this chapter and shall comply with the following standards:
- a. Maximum Distance of Off-Site Parking: Off-site parking shall be located according to the distance established in Table 21A.44.060-B, “Maximum Distances for Off-Site Parking“ (measured in a straight line from the property boundary of the principal use for which the parking serves to the closest point of the parking area).

<b>Table 21A.44.060-B: Maximum Distances for Off-Site Parking:</b>	
<b>Context</b>	<b>Maximum Distance to Off-Site Parking</b>
Neighborhood Center	600 ft.
General	
Legal Nonconforming Use in Residential District	
Urban Center	1,200 ft.
Transit	1,000 ft.

- b. Documentation Required:
- (1) The owners of record involved in an off-site parking arrangement shall submit written documentation of the continued availability of the off-site parking arrangement to the planning director for review.
  - (2) The planning director shall approve the off-site parking arrangement if the director determines the location meets the standards of this section. No zoning or use approval shall be issued until the director has approved the off-site parking arrangement and the documentation has been recorded in the office of the Salt Lake County Recorder.
  - (3) If the off-site parking arrangement is later terminated or modified and the planning director determines that the termination or modification has resulted in traffic congestion, overflow parking in residential neighborhoods, or threats to pedestrian, bicycle, or vehicle safety, the property owners of the uses for which the off-site parking was provided may be held in violation of this chapter.



5. Circulation Plan Required: Any application for a building permit shall include a site plan, drawn to scale, and fully dimensioned, showing any off street parking or loading facilities to be provided in compliance with this title. A tabulation of the number of off street vehicle and bicycle parking, loading, and stacking spaces required by this chapter shall appear in a conspicuous place on the plan.
6. Driveways and Access:
  - a. Compliance with Other Adopted Regulations:
    - (1) Parking lots shall be designed in compliance with applicable city codes, ordinances, and standards, including but not limited to Title 12 of this code: *Vehicles and Traffic* and the Off Street Parking Standards Manual to the maximum degree practicable, with respect to:
      - (a) Minimum distances between curb cuts;
      - (b) Proximity of curb cuts to intersections;
      - (c) Provisions for shared driveways;
      - (d) Location, quantity and design of landscaped islands; and
      - (e) Design of parking lot interior circulation system.
    - (2) Notwithstanding the provisions of Subsection 21A.44.060.A.6.a(1) above, relocation of a driveway for a single-family, two-family, or twin home residence in any zoning district shall only be required when the residence is replaced, and shall not be required when the residence is expanded or renovated in compliance with the city code.
  - b. Access Standards: Access to all parking facilities shall comply with the following standards:
    - (1) To the maximum extent practicable, all off street parking facilities shall be designed with vehicular access to a street or alley that will least interfere with automobile, bicycle, and pedestrian traffic movement.
    - (2) Parking facilities in excess of five (5) spaces that access a public street shall be designed to allow vehicles to enter and exit the lot in a forward direction.
    - (3) Parking facilities on lots with less than one hundred feet (100') of street frontage shall have only one curb cut, and lots with one hundred feet (100') of street frontage or more shall be limited to two curb cuts, unless the transportation director determines that additional curb cuts are necessary to ensure pedestrian, bicycle, and vehicle safety or to comply with the fire code.

Public safety uses shall be exempt from limitations on curb cuts.

(4) All vehicular access roads/driveways shall be surfaced as required in accordance with Subsection 21A.44.060.A.8, “Surface Materials”.

c. Driveway Standards: All driveways shall comply with the following standards:

(1) Driveway Location in Residential Zoning Districts: With the exception of legal shared driveways, driveways shall be at least twenty feet (20’) from street corner property lines and five feet (5’) from any public utility infrastructure such as power poles, fire hydrants, and water meters. Except for entrance and exit driveways leading to approved parking areas, no curb cuts or driveways are permitted.

(2) Driveway Widths: All driveways serving residential uses shall be a minimum eight feet wide and shall comply with the standards for maximum driveway widths listed in Table 21A.44.060-C, “Minimum and Maximum Driveway Width”.

<b>TABLE 21A.44.060-C: MINIMUM AND MAXIMUM DRIVEWAY WIDTH:</b>		
<b>Zoning District</b>	<b>Minimum Driveway Width (in front and corner side yard)</b>	<b>Maximum Driveway Width* (in front and corner side yard)</b>
SR-1, SR-2 and SR-3	8 ft.	22 ft.
MH	8 ft.	16 ft.
Other Residential Zoning Districts	8 ft.	30 ft.
M-1 and M-2	12 ft. single lane and 24 ft. for two-way	50 ft.
Other Non-Residential Zoning Districts	12 ft. single lane and 24 ft. for two-way	30 ft.
* Maximum width is for all driveways combined when more than one driveway is provided		

(3) Shared Driveways: Shared driveways, where two or more properties share one driveway access, may be permitted if the transportation director determines that the design and location of the shared driveway access will not create adverse impacts on traffic congestion or public safety.

- (4) Driveway Surface: All driveways providing access to parking facilities shall be improved and maintained pursuant to the standards in the Off Street Parking Standards Manual.
7. Minimum Dimensional Standards: All parking spaces shall comply with the dimensional standards in the Off Street Parking Standards Manual.
  8. Surface Materials: All parking spaces shall comply with the standards for surfacing of access, driving, and parking surfacing in the Off Street Parking Standards Manual.
  9. Grading and Stormwater Management: All surface parking areas shall comply with city grading and stormwater management standards and shall be reviewed for best management practices by Salt Lake City Department of Public Utilities. Refer to the Salt Lake City Stormwater Master Plan, Storm Drainage Manual, and Green Infrastructure Toolbox for additional information.
  10. Sight Distance Triangles: All driveways and intersections shall comply with the sight distance triangle standards as defined in the Off Street Parking Standards Manual.
  11. Landscaping and Screening: All parking areas and facilities shall comply with the landscaping and screening standards in Chapter 21A.48, “Landscaping and Buffers”.
  12. Lighting: Where a parking area or parking lot is illuminated, the light source shall be shielded so that the light source is not directly visible from any abutting property or abutting private or public street.
  13. Signs: All signs in parking areas or related to parking facilities shall comply with Chapter 21A.46, “Signs”, and applicable provisions of the Manual on Uniform Traffic Control Devices (MUTCD).
  14. Pedestrian Walkways:
    - a. Surface parking lots with between twenty-five (25) and one hundred (100) parking spaces shall provide a pedestrian walkway or sidewalk through the parking lot to the primary entrance of the principal building. Pedestrian walkways shall be identified by a change in color, material, surface texture, or grade elevation from surrounding driving surfaces.
    - b. Parking lots with more than one hundred (100) parking spaces shall provide:
      - (1) One or more grade-separated pedestrian walkway(s), at least five feet (5’) in width, and located in an area that is not a driving surface, leading from the farthest row of parking spaces to the primary entrance of the principal building.

- (2) Vehicles shall not overhang the pedestrian walkway(s).
- (3) Where the walkway(s) crosses a drive aisle, pedestrian walkway(s) shall be identified by a change in color, material, surface texture, or grade elevation from surrounding driving surfaces.
- (4) One pedestrian walkway meeting these standards shall be provided for each one hundred (100) parking spaces provided on site or part thereof, after the first one hundred (100) parking spaces.

15. Parking Garages: The following standards shall apply to all above-ground parking garages except those located in the FB zones subject to Subsection 21A.27.030.C.4, whether freestanding or incorporated into a building:

- a. Each façade or a parking garage adjacent to a public street or public space shall have an external skin designed to conceal the view of all parked cars. Examples include heavy gauge metal screen, precast concrete panels, live green or landscaped walls, laminated or safety glass, or decorative photovoltaic panels.
- b. No horizontal length of the parking garage façade shall extend longer than 40 feet without the inclusion of architectural elements such as decorative grillwork, louvers, translucent screens, alternating building materials, and other external features to avoid visual monotony. Facade elements shall align with parking levels.
- c. Internal circulation shall allow parking surfaces to be level (without any slope) along each parking garage facade adjacent to a public street or public space. All ramps between levels shall be located along building facades that are not adjacent to a public street or public space, or shall be located internally so that they are not visible from adjacent public streets or public spaces.
- d. The location of elevators and stairs shall be highlighted through the use of architectural features or changes in façade colors, textures, or materials so that visitors can easily identify these entry points.
- e. Interior parking garage lighting shall not produce glaring sources toward adjacent properties while providing safe and adequate lighting levels. The use of sensor dimmable LEDs and white stained ceilings are recommended to control light levels on-site while improving energy efficiency.
- f. In the Urban Center Context and Transit Context areas, the street-level facades of all parking garages shall be designed to meet applicable building code standards for habitable space to allow at least one permitted or conditional use, other than parking, to be located where the parking garage is located.

- g. Vent and fan locations shall not be located on parking garage facades facing public streets or public spaces, or adjacent to residential uses, to the greatest extent practicable.
16. Tandem Parking: Where more than one parking space is required to be provided for a residential dwelling unit, the parking spaces may be designed as tandem parking spaces, provided that:
- a. No more than two required spaces may be included in the tandem parking layout; and
  - b. Each set of two tandem parking spaces shall be designated for a specific residential unit.
17. Cross-Access Between Adjacent Uses: The transportation director may require that access to one or more lots be through shared access points or cross-access through adjacent parcels when the transportation director determines that individual access to abutting parcels or limited distance between access points will create traffic safety hazards due to traffic levels on adjacent streets or nearby intersections. Such a determination shall be consistent with requirements of state law regarding property access from public streets. Required cross-access agreements shall be recorded with the Salt Lake County Recorder's Office.

B. Zone Specific Location and Design Standards:

1. D-1, D-3, D-4, and G-MU Zoning Districts: The following regulations shall apply to surface or above-ground parking facilities. No special design and setback restrictions shall apply to below-ground parking facilities.
- a. Above-ground parking facilities located within the block corner areas and on Main Street, shall be located behind principal buildings and:
    - (1) All above-ground parking facilities that front a street shall contain uses other than parking along the entire length of the building façade and along all stories or levels of the building.
    - (2) Vehicle access to parking shall be located to the side of the building or as far from the street corner as possible unless further restricted by this title.
  - b. Parking garages shall meet the following:
    - (1) Retail goods/service establishments, offices and/or restaurants shall be provided on the first floor adjacent to the front or corner side lot line. The facades of such first floors shall be compatible and consistent with the associated retail or office portion of the building and other retail uses in the area.
    - (2) Levels of parking above the first level facing the front or corner side lot line

shall have floors and/or facades that are horizontal, not sloped.

- (3) Landscape Requirements: Surface parking lots, where allowed shall have a minimum landscaped setback of fifteen feet (15') and shall meet interior parking lot landscaping requirements as outlined in Chapter 21A.48, "Landscaping and Buffers".

2. TSA Transit Station Area District: New uses and development or redevelopment within the TSA Transit Station Area District shall comply with the following standards.

- a. Surface Parking on Corner Properties: On corner properties, surface parking lots shall be located behind principal buildings or at least sixty feet (60') from the intersection of the front and corner side lot lines.
- b. Surface Parking in the Core Area: Surface parking lots in the core area are required to be located behind or to the side of the principal building.

(1) When located to the side of a building, the parking lot shall be:

(a) Set back a minimum of thirty feet (30') from a property line adjacent to a public street. The area between the parking lot and the property line adjacent to a public street shall be landscaped or activated with outdoor dining, plazas, or similar features;

(b) Screened with a landscaped hedge or wall that is at least thirty-six inches (36") above grade and no taller than forty-two inches (42") above grade. Landscaping berms are not permitted; and

(c) No wider than what is required for two rows of parking and one drive aisle as provided in the Off Street Parking Standards Manual.

(2) Unless a second driveway is necessary to comply with the fire code, a maximum of one driveway and drive aisle shall be permitted per street frontage. The access point shall be located a minimum of one hundred feet (100') from the intersection of the front and corner side lot lines. If the front or corner side lot line is less than one hundred feet (100') in length, then the edge of the drive approach shall be located within twenty feet (20') of the side or rear property line.

c. Surface Parking in the Transition Area:

(1) Surface parking lots in the transition area are required to be located behind the principal building or to the side of a principal building.

(2) When located to the side of a principal building, the parking lot shall be:

- (a) Set back so that no portion of the parking area (other than the driveway) shall be closer to the street than the front wall setback of the building. In cases where the front wall of the building is located within five feet (5') of a property line adjacent to a street, the parking lot shall be set back a minimum of eight feet (8'). The space between the parking lot and the property line adjacent to a street shall be landscaped or activated with outdoor dining, plazas, or similar features; and
  - (b) Screened with a landscaped hedge or wall that is at least thirty-six inches (36") above grade and no taller than forty-two inches (42") above grade. Landscaped berms are not permitted.
- d. Off street parking for police services are exempt from landscape setback dimensions when off street parking is necessary for a police substation located in an existing building. This exemption permits parking for emergency vehicles when the landscape setback also fulfills any requirement for open space area on the property. The extent of the exemption shall be the minimum necessary to accommodate the necessary parking. If the police substation use vacates the space, the landscaping that was removed, if any, shall be restored in a manner that complies with the applicable regulations in place at the time the use ceases.

### C. Recreational Vehicle Parking:

#### 1. Generally:

- a. Recreational vehicle parking spaces shall be in addition to, and not in lieu of, required off street vehicle parking spaces.
- b. Recreational vehicles shall not be used for storage of goods, materials, or equipment other than those that are customarily associated with the recreational vehicle.
- c. All recreational vehicles shall be stored in a safe and secure manner. Any tie downs, tarpaulins, or ropes shall be secured from flapping in windy conditions.
- d. Recreational vehicles shall not be occupied as a dwelling while parked on the property.
- e. Recreational vehicle parking is permitted in any enclosed structure conforming to building code and zoning requirements for the zoning district in which it is located.
- f. Recreational vehicle parking outside of an approved enclosed structure shall be permitted for each residence and shall be limited to one motor home or travel trailer and a total of two recreational vehicles of any type.

- g. Recreational vehicle parking outside of an enclosed structure shall comply with the standards in this section.
2. Front Yard Parking: Recreational vehicle parking is prohibited in any required or provided front yard.
  3. Rear Yard Parking: Recreational vehicles may be parked in the rear yard when they are on a hard surfaced pad compliant with surfacing standards in the Off Street Parking Standards Manual and with access provided by either a hard surfaced driveway, hard surfaced drive strips or an access drive constructed of turf block materials with an irrigation system.
  4. Side Yard Parking: Recreational vehicle parking in side yards shall be allowed only when topographical factors, the existence of mature trees, or the existence of properly permitted and constructed structures prohibit access to the rear yard. The existence of a fence or other structure that is not part of a building shall not constitute a lack of rear yard access. Any recreational vehicle parking area in a side yard shall:
    - a. Be on a hard surface compliant with the Off Street Parking Standards Manual;
    - b. Be accessed via a driveway compliant with driveway standards of this chapter;
    - c. Not obstruct access to other required parking for the use.

SECTION 13. Amending the Text of Chapter 21A.59. That Chapter 21A.59 of the *Salt Lake City Code* (Zoning: Design Review), shall be and hereby is amended to read as follows:

CHAPTER 21A.59  
DESIGN REVIEW

SECTION:

**21A.59.010: Purpose Statement**

**21A.59.020: Authority**

**21A.59.030: Design Review Process**

**21A.59.040: Scope of Modifications Authorized**

**21A.59.045: Design Review Standards Applicability**

**21A.59.050: Standards for Design Review**

**21A.59.060: Time Limit on Approved Applications for Design Review**

**21A.59.070: Effect of Approval of Applications for Design Review**

**21A.59.080: Modifications to Approved Design Review Plans**

**21A.59.010: PURPOSE STATEMENT:**



The purpose of the design review chapter is to: a) establish a process and standards of review for minor modifications to applicable design standards, and b) ensure high quality outcomes for larger developments that have a significant impact on the city. The intent of the process to review applications for minor modifications to applicable design standards is to allow some flexibility in how the design standards are administered by recognizing that this title cannot anticipate all development issues that may arise. The intent of the process to review larger developments is to verify new developments are compatible with their surroundings, impacts to public infrastructure and public spaces are addressed, and that new development helps achieve development goals outlined in the adopted master plans of the city as identified in the purpose statements of each zoning district.

### **21A.59.020: AUTHORITY:**

Design review shall be required pursuant to the provisions of this chapter for developments and alternate building and site design features as specified within individual zoning districts before building permits may be issued.

- A. Administrative Review: The planning director may approve, approve with modifications, deny or refer to the planning commission modifications to specific design standards when proposed as new construction, an addition or modification to the exterior of an existing structure, or a modification to an existing structure as authorized in Section 21A.59.040, Table 21A.59.040 of this chapter or when authorized in the specific zoning district.
1. The director shall approve a request to modify a design standard if the director finds that the proposal complies with the purpose of the individual zoning district, the purpose of the individual design standards that are applicable to the project, the proposed modification is compatible with the development pattern of other buildings on the block face or on the block face on the opposite side of the street, and the project is compliant with the applicable design review objectives (Section 21A.59.050 of this chapter).
  2. The director may approve a request to modify a design standard with conditions or modifications to the design if the director determines a modification is necessary to comply with the purpose of the base zoning district, the purpose of the applicable design standards of the base zoning, to achieve compatibility with the development pattern of other buildings on the block face or on the block face on the opposite side of the street, or to achieve the applicable design review objectives.
  3. The director shall deny a request to modify a design standard if the design does not comply with the purpose of the base zoning district, the purpose of the applicable design standards or the applicable design review objectives and no modifications or conditions of approval can be applied that would make the design comply.
  4. The director may forward a request to modify a design standard to the planning commission if the director finds that the request for modification is greater than allowed by this chapter, a person receiving notice of the proposed modification can

demonstrate that the request will negatively impact their property, or at the request of the applicant if the director is required to deny the request as provided in this section.

B. Planning Commission Review: The following types of applications shall be reviewed by the planning commission. If an application for design review is not listed below, it shall be eligible for administrative review as outlined in Subsection A of this section:

1. All projects where planning commission review is required in the specific zoning district.
2. All projects that include a request for additional building height or a reduction to a minimum height requirement;
3. All projects that request additional square footage when authorized in the specific zoning district;
4. All projects that have applied for a modification of base zoning design standards but could not be approved administratively because they exceed limits identified in Section 21A.59.040, Table 21A.59.040 of this chapter.
5. Projects in the TSA Transit Station Area District that have a development score that requires planning commission review and approval.

C. Planning Commission Decisions: When reviewing design review applications, the planning commission may take any of the following actions:

1. The commission shall approve a project if it finds that the proposal complies with the purpose of the zoning district and applicable overlay district(s), the purpose of the individual design standards that are applicable to the project, and the project is compliant with the applicable design review objectives found in this chapter.
2. The commission may approve a project with conditions or modifications to the design if it determines a modification is necessary to comply with the purpose of the base zoning district, the purpose of the applicable design standards of the base zoning, or the applicable design review objectives.
3. The commission shall deny the design of a project if the design does not comply with the purpose of the base zoning district, the purpose of the applicable design standards or the applicable design review objectives and no modifications or conditions of approval can be applied that would make the design comply.

D. H Historic Preservation Overlay District: Modifications to design standards for properties within an H Historic Preservation Overlay District are subject to the processes and applicable standards outlined in Section 21A.34.020 of this title and not this chapter.

### **21A.59.030: DESIGN REVIEW PROCESS:**

A. Presubmittal Meeting: A presubmittal meeting with planning staff is recommended prior to submitting an application for design review to ensure a detailed understanding of the application submission requirements and design review process.

B. Complete Application: The design review application is considered complete when it includes all of the following:

1. All of the application information required for site plan review as identified in Chapter 21A.58 of this title.
2. Photos showing the facades of adjacent development, trees on the site, general streetscape character, and views to and from the site.
3. Demonstration of compliance with the purpose of the individual zoning district in written narrative and graphic images.
4. Demonstration of compliance with the purpose of the applicable design standards of the individual zoning district in written narrative, graphic images, and relevant calculations.
5. Demonstration of compliance with the applicable design review objectives (Section 21A.59.060 of this chapter) in written narrative, graphics, images, and relevant calculations.
6. The zoning administrator may waive a submittal requirement if it is not necessary in order to determine if a request for a modification to a design standard complies with the standards of review.

C. Public Notification and Engagement:

1. Notice of Application for Administrative Review: Prior to the approval of an administrative decision for a modification to a specific design standard, the Planning director shall provide written notice as provided in Chapter 21A.10 of this title.
2. Required Notice for Planning Commission Review:
  - a. Applications subject to planning commission review of this chapter are subject to notification requirements of Chapter 2.60 of this code.
  - b. Any required public hearing is subject to the public hearing notice requirements found in Chapter 21A.10 of this title.

**21A.59.040: SCOPE OF MODIFICATIONS AUTHORIZED:**

A. The authority of the planning director through the design review process shall be limited to modification of the specific element referenced within each zoning district. For planning director review, the design standards of the applicable zoning district (see Chapter 21A.37, “Design Standards”, of this title), may be modified according to the following table.

TABLE 21A.59.040

<b>Design Standards</b>	<b>Primary Modification Allowed</b>	<b>Secondary Modification Allowed</b>
A. Ground Floor Use and Visual Interest:		
1. Ground floor use only	Length: 10%	Depth: 20%
2. Ground floor use and visual interest	planning commission only	
B. Building Materials:		
1. Ground floor building materials	planning commission only	
2. Upper floor building materials	planning commission only	
C. Glass:		
1. Ground floor glass	10%	
2. Upper floor glass	10%	
D. Building Entrances	10%	
E. Maximum Length of Blank Wall	10%	
F. Maximum Length of Street- Facing Facades	10%	
G. Upper Floor Stepback:		
1. For street facing facades	20%	
2. For facades facing single- or two-family residential districts	planning commission only	

B. The planning commission may consider modifications that exceed allowances listed in this section or any other design standard modification authorized in the base zoning district or Chapter 21A.37 of this title.

**21A.59.045: DESIGN REVIEW STANDARDS APPLICABILITY:**

- A. Design Review applications shall be reviewed for compliance with the design review standards of Section 21A.59.050, as follows:
1. General Modification Requests: Applications to modify a design standard in Chapter 21A.37, or other zoning standard specifically authorized for modification through design review, shall be reviewed for compliance with the design review standards that are directly related to the purpose of the associated regulation requested for modification.

2. Additional Height or Square Footage Requests: Applications required to go through design review due to a height or square footage regulation shall be reviewed for compliance with all design review standards.
  3. Transit Station Area Requests: For properties in a Transit Station Area District, applications required to go through design review due to not meeting the minimum points for administrative approval shall be reviewed for compliance with all design review standards.
  4. All Other Requests: Any application not covered by Subsections 1 through 3 above, shall be subject to review for compliance with all design review standards.
- B. Exception: For those applications required to be reviewed against all design review standards, if an application complies with a standard in the base zoning district or with an applicable requirement in Chapter 21A.37 of this title, and that standard is directly related to a standard found in this section, the planning commission shall find that application complies with the specific standard for design review found in this section.
1. If there is no directly related zoning district standard or applicable requirement in Chapter 21A.37 of this title related to the design review standard, then the design review standard applies, and the commission shall not by default make the above finding.
- C. Alternatives: An applicant may propose an alternative to a standard for design review provided the proposal is consistent with the intent of the standard for design review.

**21A.59.050: STANDARDS FOR DESIGN REVIEW:**

- A. Any new development shall comply with the intent of the purpose statement of the zoning district and specific design regulations found within the zoning district in which the project is located as well as the city’s adopted “urban design element” and adopted master plan policies and design guidelines governing the specific area of the proposed development.
- B. Development shall be primarily oriented to the sidewalk, not an interior courtyard or parking lot.
  1. Primary entrances shall face the public sidewalk (secondary entrances can face a parking lot).
  2. Building(s) shall be sited close to the public sidewalk, following and responding to the desired development patterns of the neighborhood.
  3. Parking shall be located within, behind, or to the side of buildings.
- C. Building facades shall include detailing and glass in sufficient quantities to facilitate pedestrian interest and interaction.

1. Locate active ground floor uses at or near the public sidewalk.
2. Maximize transparency of the street facing facades by prohibiting covering the ground floor glass with reflective treatments, interior walls, and other similar features that prevent passers-by from seeing inside of the building for non-residential uses.
3. Use or reinterpret traditional storefront elements like sign bands, clerestory glazing, articulation, and architectural detail at window transitions.
4. Locate outdoor dining patios, courtyards, plazas, habitable landscaped yards, and open spaces so that they have a direct visual connection to the street and outdoor spaces.

D. Large building masses shall be divided into heights and sizes that relate to human scale.

1. Relate building scale and massing to the size and scale of existing and anticipated buildings, such as alignments with established cornice heights, building massing, step-backs and vertical emphasis.
2. Modulate the design of a larger building using a series of vertical or horizontal emphases to equate with the scale (heights and widths) of the buildings in the context and reduce the visual width or height.
3. Include secondary elements such as balconies, porches, vertical bays, belt courses, fenestration and window reveals.
4. Reflect the scale and solid-to-void ratio of windows and doors of the established character of the neighborhood or that which is desired in the master plan.

E. Building facades that exceed a combined contiguous building length of two hundred feet (200') shall include:

1. Changes in vertical plane (breaks in facade);
2. Material changes;
3. Massing changes;
4. A minimum of 80% of the ground floor must be used for active, publicly accessible uses. Active uses are those that promote an active pedestrian environment through inclusion of uses that capture the attention of a passer-by. This includes retail establishments, retail services, civic spaces (theaters, museums, etc), restaurants, bars, art and craft studios, and other uses determined to be substantially similar by the planning director and/or commission; and
5. Stepback must be a minimum of 10' from the base of the building. This allows the base to be the primary defining element for the site and the adjacent public realm, reducing wind impacts, and opening sky views.

The maximum height of the base of a proposed building should be equal to the width of the right of way if allowed in the zoning district to provide sufficient enclosure for the street without overwhelming the street. The minimum height of the base must be at least two stories.

A building over 200' in width shall include necessary separation from property lines to minimize the impact of shadows and development rights of adjacent properties.

F. If provided, privately-owned public spaces shall include at least three of the six following elements:

1. At least one sitting space for each 250 square feet shall be included in the plaza. Seating shall be a minimum of 16" in height and 30" in width. Ledge benches shall have a minimum depth of 30";
2. A mixture of areas that provide seasonal shade;
3. Trees in proportion to the space at a minimum of one tree per 800 square feet, at least 2" caliper when planted;
4. Water features or public art;
5. Outdoor dining areas; and
6. Other amenities not listed above that provide a public benefit.

G. Building height shall be modified to relate to human scale and minimize negative impacts. In downtown and in the CSHBD Sugar House Business District, building height shall contribute to a distinctive city skyline.

1. Human scale:

- a. Utilize setbacks to design a building that relate to the height and scale of adjacent and nearby buildings, or where identified, goals for future scale defined in adopted master plans.
- b. The minimum setback for any building located in a zoning district that does not contain an upper level setback provision shall be 10'. This setback is only required for applications requesting additional height when authorized in the underlying zoning district. The setback shall be applied to the first full floor of the building that is seeking the request for additional height.
- c. For buildings more than three stories or buildings with vertical mixed use, compose the design of a building with distinct base, to reduce the sense of apparent height.

2. Negative impacts: All buildings seeking additional height as authorized in the underlying zoning district shall be subject to the following standards:

- a. Modulate taller buildings vertically and horizontally so that it steps up or down to its neighbors.
- b. Minimize shadow impacts of building height on the public realm and semi-public spaces by varying building massing. Demonstrate impact from shadows due to building height for the portions of the building that are subject to the request for additional height.

- c. Modify tall buildings to minimize wind impacts on public and private spaces, such as the inclusion of a wind break above the first level of the building.
  - d. Design and orient to prevent snow, ice, or water from falling directly onto a public sidewalk, public space, neighboring property, or directly onto the walkway leading to the building entrance.
3. Cornices and rooflines:
- a. Cohesiveness: Shape and define rooflines to be cohesive with the building's overall form and composition. The roofline and architectural detailing, including cornices, shall be complimentary to the structure's scale, material, color, and form and create a change in plane of at least 6 inches, a change in material, utilizing at least one visible sloping plan along a minimum of 50% of the roofline on building elevations facing a street, or a change in material orientation to define the roof line of the building.
  - b. Green Roof and Roof Deck: Include a green roof and/or accessible roof deck to support a more visually compelling roof landscape and reduce solar gain, air pollution, and the amount of water entering the stormwater system.
- H. Parking and on site circulation shall be provided with an emphasis on making safe pedestrian connections to the sidewalk, transit facilities, or midblock walkway. Parking is encouraged to be behind the principal building and away from pedestrian walkways.
- Parking lots and structures shall be setback a minimum of 25' from required midblock pedestrian access locations or as required in the underlying zoning district if the underlying zoning requires a larger setback.
- I. Waste and recycling containers, mechanical equipment, storage areas, and loading docks shall be fully screened from public view and, for buildings with only one street-facing frontage, are prohibited from being located along street-facing facades. They shall incorporate building materials and detailing compatible with the building being served and shall be co-located with driveways unless prohibited by the presence of a street tree, public infrastructure, or public facility within the right of way. Service uses may be located within the structure. (See Subsection 21A.37.050.K of this title.)
- J. Signage shall emphasize the pedestrian/mass transit orientation.
- 1. Define specific spaces for signage that are integral to building design, such as commercial sign bands framed by a material change, columns for blade signs, or other clearly articulated band on the face of the building.
  - 2. Coordinate signage locations with appropriate lighting, awnings, and other projections.
  - 3. Coordinate sign location with landscaping to avoid conflicts.



K. Lighting shall support pedestrian comfort and safety, neighborhood image, and dark sky goals.

1. Provide street lights as indicated in the Salt Lake City Lighting Master Plan.
2. Outdoor lighting should be designed for low-level illumination and to minimize glare and light trespass onto adjacent properties and uplighting directly to the sky.
3. Coordinate lighting with architecture, signage, and pedestrian circulation to accentuate significant building features, improve sign legibility, and support pedestrian comfort and safety.

L. Streetscape improvements shall be provided as follows:

1. One street tree chosen from the street tree list consistent with the city's urban forestry guidelines and, with the approval of the city's urban forester, shall be placed for every 30' of property frontage on a street. Existing street trees removed as the result of a development project shall be replaced by the developer with trees approved by the city's urban forester.
2. Hardscape (paving material) shall be utilized to differentiate privately-owned public spaces from public spaces. Hardscape for public sidewalks shall follow applicable design standards. Permitted materials for privately-owned public spaces shall meet the following standards:
  - a. Use materials that are durable (withstand wear, pressure, damage), require a minimum of maintenance, and are easily repairable or replaceable should damage or defacement occur.
  - b. Where practical, as in lower-traffic areas, use materials that allow rainwater to infiltrate into the ground and recharge the water table.
  - c. Limit contribution to urban heat island effect by limiting use of dark materials and incorporating materials with a high Solar- Reflective Index (SRI).
  - d. Utilize materials and designs that have an identifiable relationship to the character of the site, the neighborhood, or Salt Lake City.
  - e. Use materials (like textured ground surfaces) and features (like ramps and seating at key resting points) to support access and comfort for people of all abilities.
  - f. Asphalt shall be limited to vehicle drive aisles.

**21A.59.060: TIME LIMIT ON APPROVED APPLICATIONS FOR DESIGN REVIEW:**

No design review approval shall be valid for a period longer than one year from the date of approval unless a building permit is issued or a complete building plans and building permit applications have been submitted to the Division of Building Services and Licensing. An extension of one year may be granted by the entity that approved the application. Extension requests must be submitted prior to the expiration of the design review approval.

**21A.59.070: EFFECT OF APPROVAL OF APPLICATIONS FOR DESIGN REVIEW:**

- A. The approval of a design review application shall authorize the preparation, filing and processing of applications for any permits or approval that may be required by the city, including, but not limited to, a building permit.
- B. Following the approval of a design review application, any future alteration to the property, building or site shall comply with the approved design review application unless a modification is approved subject to the process outlined in this chapter.

**21A.59.080: MODIFICATIONS TO APPROVED DESIGN REVIEW PLANS:**

- A. Minor Modifications: The planning director may authorize minor modifications to approved design review applications as listed below.
  - 1. Dimensional requirements that are necessary in order to comply with adopted building codes, fire codes, or engineering standards. The modification is limited to the minimum amount necessary to comply with the applicable building code, fire codes, or engineering standard.
  - 2. Minor changes to building materials provided the modification is limited to the dimension of the material, color of material, or texture of material. Changes to a different material shall not be considered a minor modification.
  - 3. Modifications other than those listed in Subsections 1 and 2 that comply with an applicable standard in this Title provided the standard was not subject to a requested modification as part of this process or any other process authorized by this title and does not conflict with a specific condition of approval or a finding associated with the approval.
- B. Other Modifications: Any other modifications not listed in Subsection A of this section shall be processed as follows:
  - 1. If the proposed modification does not require a change to a condition of approval or a finding that was identified in a staff report or record of decision the matter may be reviewed by the planning commission, or in the case of administrative approvals, by the planning director, as a reconsideration of that specific modification subject to a public hearing for planning commission decisions or a notice of application for administrative approvals.
  - 2. Any other modification shall require a new application and be subject to all required processes and standards.

SECTION 14. Amending the Text of Subsection 21A.27.050.D (Contingent on Adoption of the FB-UN3 District). That, if Subsection 21A.27.050.D of the *Salt Lake City Code* (Zoning: Form Based Districts: FB-UN1, FB-UN2, and FB-UN3 Form Based Urban Neighborhood District) is adopted by the date of the City Council adopting this ordinance, that subsection shall be and hereby is amended to read as follows:

21A.27.050.D. FB-UN3 Building Form Standards:  
 Building form standards for each allowed building form and other associated regulations for the FB-UN3 zone are listed in the below tables of this section.

1. Row House Building Form Standards:  
 TABLE 21A.27.050.D.1

<b>Building Regulation</b>		<b>Regulation for Building Form: Row House</b>
H	Height	Maximum of 40'. All heights measured from established grade. Rooftop decks and associated railing/parapet are allowed on any roof, including roofs at the maximum allowed height.
F	Front and Corner Side Yard Setback	Minimum 5'. Maximum 10', unless a greater setback is required due to existing utility easements in which case the maximum setback shall be at the edge of the easement. May be modified through Design Review (Chapter 21A.59).
S	Interior Side Yard	Minimum of 5' between row house building form and side property line, except when an interior side yard is adjacent to a zoning district that has a maximum permitted building height of 30' or less, then the minimum shall be 10'. For the purpose of this regulation, an alley that is a minimum of 10' in width that separates a subject property from a different zoning district shall not be considered adjacent. No setback required for common walls.
R	Rear Yard	Minimum of 5' between row house building form and rear property line, except when rear yard is adjacent to a zoning district with a maximum permitted building height of 30' or less, then the minimum is 20'. For the purpose of this regulation, an alley that is a minimum of 10' in width that separates a subject property from a different zoning district shall not be considered adjacent.
U	Uses Per Story	Residential on all stories; live/work units permitted on ground level.

GU	Ground Floor Use on 900 South	The required ground floor use space facing 900 South must be occupied by a live/work space at least 25' in depth. Dimensions may be modified through Design Review (Chapter 21A.59).
E	Entry Feature	Each dwelling unit must include an allowed entry feature. See Table 21A.27.030B for allowed entry features. Dwelling units adjacent to a street must include an entry feature on street facing façade. Pedestrian connections, as per Subsection 21A.27.030.C.5, with minimum 5' width are required for each required entry feature.
U	Upper Level Stepback	When adjacent to a lot in a zoning district with a maximum building height of 30' or less, the first full floor of the building above 30' shall step back 10' from the building façade at finished grade along the side or rear yard that is adjacent to the lot in the applicable zoning district. This regulation does not apply when a lot in a different zoning district is separated from the subject parcel by a street or alley.
OS	Open Space Area	Each dwelling unit shall include a minimum open space area that is equal to at least 25% of the footprint of the individual unit, subject to all other open space area requirements of Subsection 21A.27.030.C.1 "Open Space Area." A minimum of 20% of the required open space area shall include vegetation.
BF	Building Forms Per Lot	Multiple buildings may be built on a single lot provided all of the buildings have frontage on a street. All buildings shall comply with all applicable standards.
SO	Side/Interior Orientation	Dwelling units not located directly adjacent to a street are permitted, provided the design standards for glass are complied with on the façade with the required entry feature. Lots for individual row house dwelling units without public street frontage are allowed subject to recording a final subdivision plat that:  <ol style="list-style-type: none"> <li>1. Documents that new lots have adequate access to a public street by way of easements or a shared driveway; and</li> <li>2. Includes a disclosure of private infrastructure costs for any shared infrastructure associated with the new lot(s) per Section 21A.55.110 of this title.</li> </ol>
MW	Midblock Walkway	If a midblock walkway is shown in an adopted city plan on the subject property, a midblock walkway shall be provided. The midblock walkway must be a minimum of 10' wide and include a minimum 6' wide unobstructed path.
DS	Design Standards	See Section 21A.27.030 and Chapter 21A.37 for other applicable building configuration and design standards.

2. Multi-Family Residential, Storefront, and Vertical Mixed-Use Building Form Standards:

TABLE 21A.27.050.D.2

<b>Building Regulation</b>		<b>Regulation for Building Forms: Multi-family Residential/Storefront/Vertical Mixed Use</b>
H	Height	Maximum height of 125'. All heights measured from established grade. Buildings in excess of 85' require design review in accordance with Chapter 21A.59. Rooftop decks and associated railing/parapet are allowed on any roof, including roofs at the maximum allowed height.
GH	Ground Floor Height	Minimum ground floor height 14'.
F	Front and Corner Side Yard Setback	No minimum is required; however, doors are prohibited from opening into the public right of way. Maximum 10' unless a greater setback is required due to existing utility easements in which case the maximum setback shall be at the edge of the easement. May be modified through Design Review process (Chapter 21A.59).
B	Required Build-To	Minimum of 50% of street facing facade shall be built within 5' of the front or corner side property line. May be modified through Design Review process (Chapter 21A.59).
S	Interior Side Yard	No minimum required, except when an interior side yard is adjacent to a zoning district that has a maximum permitted building height of 30' or less, then the minimum shall be 10'. For the purpose of this regulation, an alley that is a minimum of 10' in width that separates a subject property from a different zoning district shall not be considered adjacent.
R	Rear Yard	No minimum required, except when rear yard is adjacent to a zoning district with a maximum permitted building height of 30' or less, then the minimum is 20'. For the purpose of this regulation, an alley that is a minimum of 10' in width that separates a subject property from a different zoning district shall not be considered adjacent.
GU	Ground Floor Use on 900 South	The required ground floor use space facing 900 South shall be limited to the following uses: retail goods establishments, retail service establishments, public service portions of businesses, restaurants, taverns/brewpubs, bar establishments, art galleries, theaters, or performing art facilities.
E	Ground Floor Dwelling Entrances	Ground floor dwelling units adjacent to a street must have an allowed entry feature. See Table 21A.27.030B for allowed entry features. Pedestrian connections, as per Subsection 21A.27.030.C.5, are required to each required entry feature.

U	Upper Level Stepback	When adjacent to a lot in a zoning district with a maximum building height of 30' or less, the first full floor of the building above 30' shall step back 10' from the building facade at finished grade along the side or rear yard that is adjacent to the lot in the applicable zoning district. This regulation does not apply when a lot in a different zoning district is separated from the subject parcel by a street or alley.
M W	Midblock Walkway	If a midblock walkway is shown in an adopted city plan on the subject property, a midblock walkway shall be provided. The midblock walkway must be a minimum of 10' wide and include a minimum 6' wide unobstructed path.
BF	Building Forms Per Lot	Multiple buildings may be built on a single lot provided all of the buildings have frontage on a street. All buildings shall comply with all applicable standards.
OS	Open Space Vegetation	A minimum of 20% of the required open space area shall include vegetation.
LB	Loading Bay	Maximum of one (1) loading bay on a front façade per street face, subject to all dimensional requirements in Section 21A.44.070. Loading bay entry width limited to 14' and must be screened by garage door. One loading bay driveway is allowed in addition to any other driveway allowances.
DS	Design Standards	See Section 21A.27.030 and Chapter 21A.37 for other applicable building configuration and design standards.

SECTION 15. Effective Date. This ordinance shall become effective on the date of its first publication.

Passed by the City Council of Salt Lake City, Utah, this \_\_\_\_\_ day of \_\_\_\_\_, 2023.

\_\_\_\_\_  
CHAIRPERSON

ATTEST AND COUNTERSIGN:

\_\_\_\_\_  
CITY RECORDER

Transmitted to Mayor on \_\_\_\_\_.

Mayor's Action: \_\_\_\_\_ Approved. \_\_\_\_\_ Vetoed.

\_\_\_\_\_  
MAYOR

\_\_\_\_\_  
CITY RECORDER  
(SEAL)

Bill No. \_\_\_\_\_ of 2023.

<p><b>APPROVED AS TO FORM</b> Salt Lake City Attorney's Office Date: <u>April 17, 2023</u> By: <u><i>Paul C. Nielson</i></u> Paul C. Nielson, <i>Senior City Attorney</i></p>
---